

USE AND MAINTENANCE MANUAL

TRANSLATION OF ORIGINAL INSTRUCTIONS

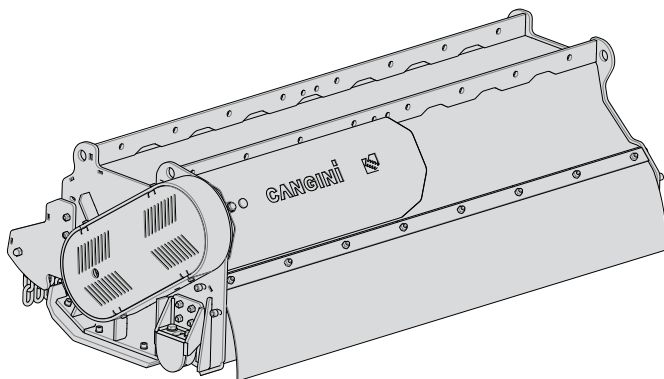

Ed. 10-3 dated 27/09/2021

MULCHER TC





ATTENTION
THE ORIGINAL INSTRUCTIONS ARE AVAILABLE TO
THE CLIENT.
CONTACT CANGINIBENNE S.R.L. FOR A COPY.

 **WARNING**
MACHINE SERVICE LIFE

The machine's service life is 5 YEARS.

Once 5 YEARS have passed after the construction date marked on the nameplate, the machine must be overhauled by a CANGINIBENNE s.r.l. authorised service centre.

For the necessary arrangements, contact the CUSTOMER CARE SERVICE:

Tel. 0039 - 0547 - 698020

Fax. 0039 - 0547 - 698021

E-mail: service@canginibenne.com

CANGINIBENNE S.R.L. sets the attachment's END OF LIFE AT 10 YEARS, unless it is dispatched to the Constructor for a general overhaul.

CANGINIBENNE srl

Via Savio, 29/31 - 47027 Sarsina FC - Italy
tel. 0039 0547 698020 - fax 0039 0547 698021

commerciale@canginibenne.com
www.canginibenne.com

DECLARATION OF CONFORMITY



PREPRINTED STICKER
Declaration of Conformity

CanginiBenne, in its capacity as constructor, declares that all parts of this interchangeable attachment comply with Directive **THE SUPPLY OF MACHINERY (SAFETY) REGULATIONS 2008** and the following standards: UNI EN ISO 12100:2010

The Technical File is established by **CanginiBenne s.r.l.**

Intended use: Interchangeable attachment.

CANGINIBENNE srl

Via Savio, 29/31 - 47027 Sarsina FC - Italy
tel. 0039 0547 698020 - fax 0039 0547 698021

commerciale@canginibenne.com
www.canginibenne.com

DECLARATION OF CONFORMITY

PREPRINTED STICKER
Declaration of Conformity

CanginiBenne, in its capacity as constructor, declares that all parts of this interchangeable attachment comply with Directive **2006/42/CE** and the following standards: UNI EN ISO 12100:2010

The Technical File is established by **CanginiBenne s.r.l.**

Intended use: Interchangeable attachment.

TABLE OF CONTENTS

1	GENERAL INTRODUCTION.....	9	5.2.5	Hydraulic slewing ring (optional).....	31
1.1	Glossary and terminology.....	9	5.3	Operating principle.....	31
2	GENERAL SAFETY PRECAUTIONS	10	6	TECHNICAL DATA.....	32
2.1	How to use the manual.....	11	6.1	Specifications and main dimensions	32
2.1.1	Symbols used.....	11	6.2	Applicability limits.....	34
2.2	Spare parts.....	12	6.3	Ambient conditions.....	35
2.3	After-sales service	12	7	Handling	36
2.4	Enclosed documentation.....	12	7.1	Lifting.....	36
3	SAFETY	13	8	INSTALLATION.....	37
3.1	Safety with regard to the attachment.....	13	8.1	Attachment mounting and removal instructions	37
3.2	Safety at work.....	14	8.1.1	Mounting on the attachment support frame	37
3.3	Minimum operator skill level required.....	14	8.1.2	Instructions for demounting the attachment....	40
3.4	Protective clothing.....	15	8.1.3	Installation on mini-excavators with quick coupling system.....	41
3.5	Working zone - danger zone - no entry zone	16	8.1.4	Uncoupling the attachment.....	42
3.6	Safety stickers.....	17	8.2	Connections	43
3.6.1	Safety signs.....	17	8.2.1	Hydraulic connection.....	43
3.7	Intended use.....	20	8.3	Maintenance and installation devices.....	46
3.8	Misuse	20	8.3.1	Drive belt and belt stretcher.....	46
3.9	Reasonably foreseeable misuse	21	8.3.2	Working tools.....	50
4	GENERAL INFORMATION	22	8.3.3	Recommendations for use.....	51
4.1	Nameplate	22	8.4	Safety devices.....	52
4.2	Model and type.....	23	8.4.1	Safety flaps.....	52
4.3	Manufacturer	23	9	USING THE Attachment	53
4.4	UKCA MARKING.....	23	9.1	Conditions of use	53
4.5	EC Marking.....	23	9.2	Operation.....	54
4.6	Relevant standards	23	9.2.1	TC0 mulching head - Reversing the rotation direction.....	54
5	Description of the implement	24	9.3	Adjusting the attachment	55
5.1	General description.....	24	9.3.1	Adjusting the cutting height - on TC1, TC2, TC3, TC4 models	55
5.2	Main components.....	24	9.4	Travel on the public highway	56
5.2.1	Front floating device (for front Mulcher only)	24	9.5	Lengthy lay-offs	56
5.2.2	Implement swing	26	9.6	Scrapping	57
5.2.3	Mechanical position adjustment system (for front TC2F - TC3F - TC4F Mulcher only)....	27	10	OPTIONAL KITS	58
5.2.4	Floating device on mini- excavators (optional) - for TC1, TC2, TC3, TC4 only	28	10.1	Hydraulic side shift system	58

10.1.1	Connection and operation of the electric kit provided	59
10.1.2	Electrical connection for optional hydraulic side shift	61
11	MAINTENANCE	62
11.1	Routine maintenance	64
11.2	Maintenance Procedures	65
11.2.1	Greasing	65
11.2.2	Grease points	66
11.2.3	Changing the knives	67
11.2.4	Replacing the guards	69
11.2.4.1	Replacing the stone guard chains (for TC1, TC2, TC3, TC4 only)	69
11.2.4.2	Replacing the stone guard skirts (for TC0 only)	69
12	TROUBLESHOOTING	70
13	WARRANTY CONDITIONS	71
13.1	Items not covered by the warranty	71
14	ANNEXES	73
14.1	ANNEX - A - Extraordinary maintenance log	73
14.2	ANNEX - B electrical - hydraulical system with regulator valves	74
14.2.1	TC Mulcher models TC0	74
14.2.2	TC Mulcher models TC1, TC2 and TC1F... ..	75
14.2.3	TC Mulcher model TCF2	76
14.2.4	TC Mulcher models TC3 and TC4 (gear motor)	77
14.2.5	TC Mulcher models TC3 and TC4 (piston motor)	78
14.2.6	TC Mulcher models TCF3 and TCF4 (gear motor)	79
14.2.7	TC Mulcher models TCF3 and TCF4 (piston motor)	80

1 GENERAL INTRODUCTION

This manual provides all necessary information for the safe use and maintenance of the **CANGINIBENNE** attachment.



ATTENTION

This attachment is classified as interchangeable, compliant with directive 2006/42/CE and UKCA The Supply of Machinery (Safety) Regulations 2008. In the event that it is mounted on a vehicle approved for use on the public highway, in order to comply with the highway code it must be registered in the vehicle's logbook by the user.



ATTENTION

The machine-attachment hitching system may vary depending on the model of machine. For couplings other than those described in this manual, follow the instructions in the machine use and maintenance manual.

The instructions provided in this manual and on the machinery are intended mainly for the operator and contain all information on potential permitted uses, for the safe operation of the machinery.



DANGER

It is essential to read this manual before using the attachment. Most accidents at work are due to the failure to comply with safety regulations or take elementary precautions.

1.1 GLOSSARY AND TERMINOLOGY

The attachment covered by this manual “Mulcher TC” will be referred to hereinafter as the “**Attachment**”, while the machine on which it is mounted will be referred to as the “**MACHINE**”.

The “**OPERATOR**” is the person or persons installing, operating, adjusting, maintaining, cleaning, repairing or moving the attachment.

A “**DANGER ZONE**” is any zone within and/or around machinery in which a person is subject to a risk to his health or safety.

An “**EXPOSED PERSON**” is any person wholly or partially in a danger zone.

The terms “**RIGHT/LEFT**” are as seen by an operator sitting in the driver's seat of the machine and facing the attachment.

2 GENERAL SAFETY PRECAUTIONS

The safe operation of the implement depends first and foremost on the people who work with it every day.

It is therefore important for operators to have detailed information about its correct operation, use and maintenance.

Constant compliance with the instructions provided in this manual guarantees that the implement will provide top performance in economical operation over a long working life.

It is everyone's interest that:

- these instructions are complied with;
- the purchaser ensures that the manual constitutes an integral part of the implement and that the operator actually uses it;
- the instructions it contains are strictly complied with, accepting full responsibility for ensuring this.

The person directly responsible for the implement and all the jobs which depend on it is the operator.

Once it has been read all the way through and its contents learnt, this manual must be kept, intact, on the machine, so that it is always available. Contact the Manufacturer for any kind of after-sales service.

It is the responsibility of operators and maintenance staff to read this manual carefully before using or maintaining the implement.

This manual must always be at operators' disposal. If the implement is resold, it is the duty of the dealer also to consign the operator's manual.

The final customer is entitled to request the dealer to provide the operator's manual with the **EC** declaration on the first page and **UKCA** declaration on the second page.



ATTENTION

The descriptions provided in this publication are not binding. The manufacturer reserves the right to make all changes it considers appropriate without any notice and without any obligation to third parties.

2.1 HOW TO USE THE MANUAL



ATTENTION

On consignment of this manual, check all data and report any discrepancies immediately.



DANGER

In this manual, some illustrations show the machine with panels or covers removed for the sake of clarity. Do not use the machine with protective panels or covers removed.

2.1.1 Symbols used

For clear understanding of the information provided in this manual, instructions considered critical or dangerous are highlighted with the following symbols:



DANGER

Information or a message which must be complied with strictly to avoid the risk of serious personal injury or death.



WARNING

Information which must be complied with strictly to avoid the risk of minor or moderate injuries or serious damage to the implement.



ATTENTION

Information or precaution which must be taken to avoid procedures which may damage the implement, or part of the text which requires highlighting.



PROTECT THE ENVIRONMENT

Underlines the importance of the instructions which follow this symbol with regard to environmental protection.

The symbols and notes are completed by messages which specify the nature of the hazards or warnings and explicitly describe the recommended procedures or the useful information to be complied with to prevent hazardous situations.

2.2 SPARE PARTS

To ensure that the implement continues in perfect working order, remember only genuine spare parts must be used during any repairs or replacements.

When ordering spare parts specify:

- the implement's serial number:
- the code number of the part required and the quantity.

2.3 AFTER-SALES SERVICE

If in doubt about the use or maintenance of the implement, contact the manufacturer.



WARNING

The manufacturer declines all responsibility for accidents or damage arising from failure to comply with the rules and instructions listed in this manual and failure to comply with the safety and accident prevention regulations in force in the various countries.

2.4 ENCLOSED DOCUMENTATION

The following attachments are an integral part of this instruction manual:

- extraordinary maintenance log.
- Hydraulic system with regulator valves.

3 SAFETY



ATTENTION

This manual contains the safety instructions for the CanginiBenne Srl attachment mounted on the various machines (skid steer loaders - backhoe loaders - wheel loaders - telehandlers - excavators). Therefore, this manual must be used together with that of the relevant machine, and the rules and recommendations it contains must be complied with.



DANGER

Correct, appropriate installation on the machine is fundamental for the attachment's safety and correct operation and must be carried out by a specialist service centre.



DANGER

The skilled operator must not take drugs or mind-altering substances or drink alcoholic beverages which might impair his mental and physical faculties when at work.

3.1 SAFETY WITH REGARD TO THE ATTACHMENT

The Manufacturer does not accept any responsibility for accidents arising from failure on the part of the user to comply with the relevant laws, regulations, recommendations and rules.

Read the following carefully and comply with it at all times:

- the attachment must only be used by authorised staff trained in its use;
- all phases of the installation, maintenance and use of the attachment must be carried out by skilled, competent staff;
- use of the attachment for lifting or transporting people is absolutely forbidden;
- use of the attachment when not completely or correctly mounted on the machine is absolutely forbidden;
- the attachment must only be used for the purpose intended by the manufacturer. Any other use constitutes misuse and is also potentially dangerous;
- the signs and stickers indicating how to use the attachment and warning of dangers must not be removed, concealed or defaced.

3.2 SAFETY AT WORK

The careful operator is the best operator; most accidents can be prevented by following a few fundamental safety rules.

Read the following carefully and comply with it at all times:

- maintenance work on the attachment must always be done with the machine at a standstill and in a stable position;
- check that there are no obstacles in the working area;
- during maintenance or adjustment of some parts of the attachment, hands must not be used to perform operations for which there are specific tools;
- never use tools which are in poor condition, nor use them improperly (e.g. pliers instead of spanners, etc.);
- never perform maintenance and/or adjustments in poorly-lit locations;
- do not stand within the machine's operating range;
- during mounting and removal of the attachment, the operator must ensure that there is no-one within the working area;
- when possible and/or necessary, fence off the working area and do not allow unauthorised access;
- the people authorised to access the machine's working area must always stay in a position where they are perfectly visible to the operator;
- stop work immediately if there are unauthorised staff within the machine's operating range.

3.3 MINIMUM OPERATOR SKILL LEVEL REQUIRED

The staff assigned to use the attachment must have:

- basic technical training with experience in the engineering and plant sector;
- specific training in the operation and use of the attachment;
- read and understood this manual completely;
- perfect familiarity with the relevant safety and accident prevention regulations.

3.4 PROTECTIVE CLOTHING

The provision and use of the following personal protection attachment (PPE - not supplied by Manufacturer) is compulsory:

- overalls or other garments which are comfortable, not too loose-fitting and without parts which may become entangled on moving parts;
- safety helmet;
- protective gloves;
- safety footwear.

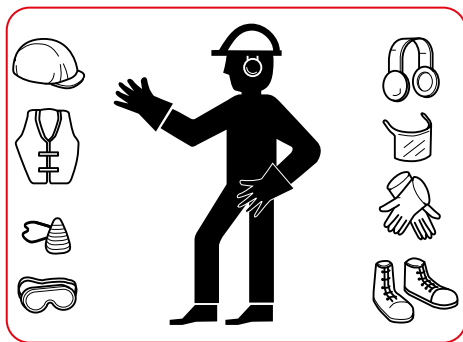

If operating conditions require it, the following must be provided:

- respirators (or dust masks);
- ear plugs or ear defenders;
- goggles or masks to protect the eyes;
- reflective clothing;
- waterproof clothing and non-slip footwear.



ATTENTION

Use only approved personal protection attachment in good condition.

3.5 WORKING ZONE - DANGER ZONE - NO ENTRY ZONE

The **WORKING ZONE** is the area in the proximity of the machine in which only authorised staff familiar with the machine's operating capacities may work. The working zone must be identified by suitable signs, even when operating in a zone already fenced.

A **DANGER ZONE** is any zone within and/or around machinery in which a person is subject to a risk to his health or safety. Since the greatest risks occur when an operator prepares to adjust, clean or perform maintenance on the machine or carry out any other manual operations required, these operations must be undertaken with the greatest care.

When the machine is running and at work, the zone around the machine becomes a **NO-ENTRY ZONE**. It must not be entered while the machine is in operation.



WARNING



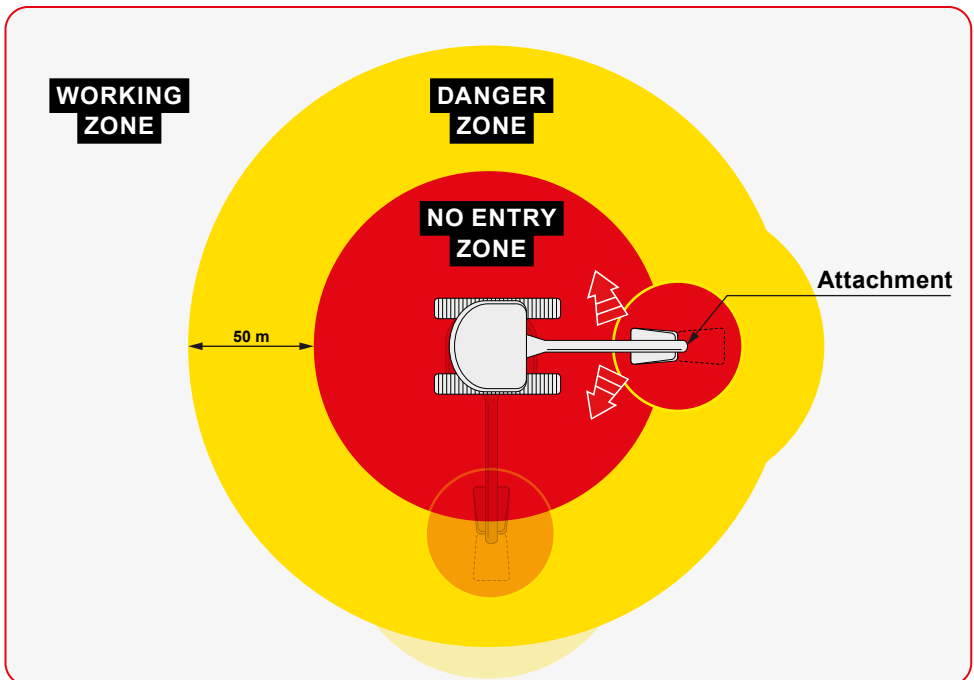

The example below is purely guideline. The safety measures detailed in this manual apply to all the machines on which the implement is mounted.







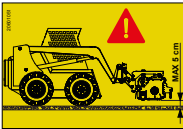

3.6 SAFETY STICKERS

3.6.1 Safety signs

The table below lists the safety signs.

SYMBOL	CODE	MEANING
	20600051	<p>Operator's Manual must be read: before starting to use or maintain the implement, staff must have read and understood the Operator's Manual supplied.</p> <p>Ignition key must be removed: before maintenance work on the implement, staff must stop the machine and remove the ignition key.</p>
	20600166	<p>No passing or standing within operating range: during use of the implement, no staff except the operative using the implement must pass or stand within its operating range (at least 50 metres from the implement in all directions).</p>
	20600062	<p>Limb injury hazard: do not place hands or feet underneath or inside any part of this implement, with the tools running; keep a safe distance from the implement during use.</p>
	20600060	<p>Entrapment hazard: if the protective casing has to be removed, do this with the machine off and the ignition key removed.</p>
	20600195	<p>Upper limb crushing and shearing hazard: keep a safe distance from the implement during use.</p>
	20600237	<p>Handling: in the travel operations, do not lift the equipment above the height indicated in the sign (MAX5cm).</p>

SYMBOL	CODE	MEANING
	20600066	Lifting points: for safe handling of the implement, connect it to the points provided, marked with the relevant sticker. Use suitable lifting equipment and regulation accessories.
	20600065	Work gloves must be worn: During operation and maintenance of the implement, always wear type-approved work gloves in good condition.
	20600066	Helmet must be worn: During operation and maintenance of the implement, always wear type-approved protective helmet in good condition.
	20600066	Safety footwear must be worn: During operation and maintenance of the implement, always wear type-approved safety shoes in good condition.
	20600066	Ear defenders: it may be necessary to wear ear defenders during use of the implement.
	20600052	Grease point: inject lubricating grease at the indicated time intervals. As well as in the position shown in the figure, this decal is affixed at all points where grease nipples are found.

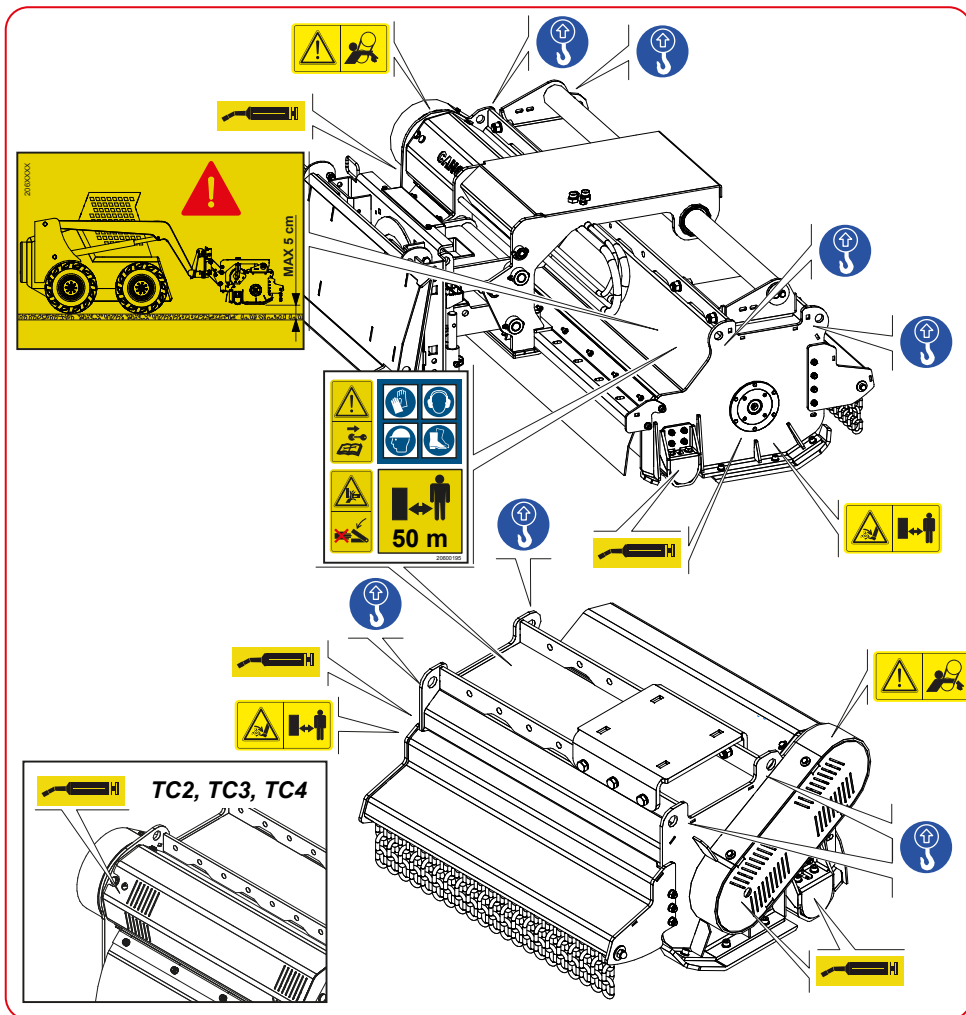
**ATTENTION**

Check every day and before every shift that the signs are in good condition and clearly legible. Replace them at once if they become damaged and ineffective, ordering duplicates directly from the manufacturer.

**WARNING**

Use of the implement without one or more signs exposes the operator to unacceptable residual risks and must therefore be prevented.

3.7 INTENDED USE

The implement has been designed and built to clean and collect refuse from large outdoor areas such as roadways, depots, embankments and car parks.

It can be mounted on skid steer and wheeled loaders.

Any other use is in contravention of the intended use and thus constitutes misuse; it is therefore forbidden.

Compliance with and observance of the conditions for the use and maintenance of the implement specified by the manufacturer are a fundamental part of its intended use.

Use and maintenance procedures must always be carried out by trained staff familiar with the implement's characteristics, in accordance with the safety instructions.

All relevant legal occupational health and safety requirements must be complied with.



ATTENTION

Any technical and construction modifications and/or extraordinary maintenance procedures not specifically authorised in this manual render the manufacturer's residual risk reduction measures ineffective; a new risk assessment procedure with a new CE marking is therefore required.



ATTENTION

The manufacturer declines all responsibility for accidents or damage arising from failure to comply with the rules and instructions listed in this manual and failure to comply with the safety and accident prevention regulations in force in the various countries.

3.8 MISUSE

Misuse is the use of the implement on criteria which do not comply with the instructions provided in this manual and which are dangerous for the operator or others.



DANGER

The most frequent examples of misuse are listed below:

- *use of the implement for lifting people or objects;*
- *failure to comply with the use and maintenance instructions provided in this manual;*
- *connection of the implement to a machine which does not have the necessary technical*

- characteristics;*
- *working beyond the implement's operating limits;*
 - *connection of the implement to a machine which does not meet the Applicability Limit;*
 - *operation with people not at the specified safe distance from the machine;*
 - *operation in potentially explosive environments;*
 - *operation in a corrosive atmosphere;*
 - *operation indoors;*
 - *operation in atmospheres with dust which may harm the operator's health.*
 - *Rotating the cutter element with the implement not resting on the ground;*
 - *using the implement on gravel, unpaved roads, shingle, rubble and stones;*
 - *working with the implement partially or totally immersed in liquids;*
 - *approaching objects, people and animals, even if the cutter element is not turning;*
 - *using the implement as a support for the machine's boom;*
 - *using the implement to move, load or handle heavy items.*
 - *using the implement to level uneven ground;*
 - *using the implement with damage to the protective screen of chains.*

**DANGER**

Improper use may damage the implement and may thus generate hazards for the staff assigned to use it.

**DANGER**

Compliance with and strict observance of the conditions for use and maintenance specified by the manufacturer are fundamental for the implement's intended use.

As well as being dangerous for the user and other people and potentially damaging to the machine, its improper use leads to the irreparable loss of warranty cover.

3.9 REASONABLY FORESEEABLE MISUSE

The following practices are defined as “reasonably foreseeable misuse” and expose the operator to unacceptable residual risks:

- working without checking that there is no-one inside the no-entry zone;
- carrying out maintenance without first stopping moving parts and lowering the implement to the ground, stopping the engine and removing the ignition key from the machine.

The manufacturer therefore draws attention to these potential uses in order to make the operator aware of them and underline the need to comply with safe operating conditions (intended use).

4 GENERAL INFORMATION



ATTENTION

Check that the operator's manual corresponds to the implement in question. When requesting information and/or after-sales service, always specify the model and serial number embossed on the nameplate.

4.1 NAMEPLATE

The manufacturer's nameplate with the product's technical data is normally affixed in the position shown by the arrow below.

This position may vary depending on the machine's linkage type and configuration.



ATTENTION

If the nameplate is lost or defaced, a copy must be requested immediately to the manufacturer (always specify the model and serial number as given in the Declaration of page 3).

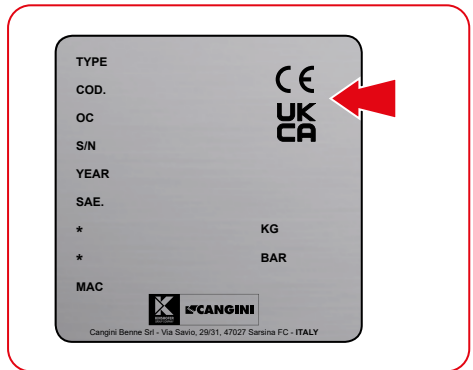
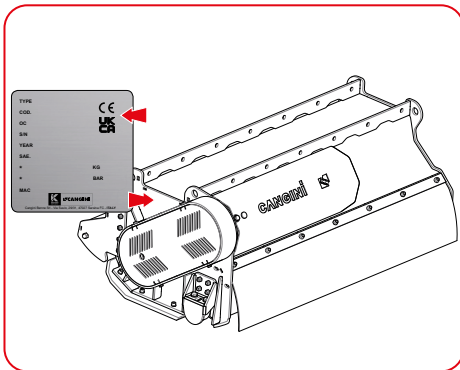

ATTENTION

Place an X (X) in the relevant box, after checking the type on the nameplate.



ATTENTION

Make a note of the serial number on the nameplate to ensure that it is to hand when communicating with the dealer or manufacturer (e.g. when requesting service under warranty).

4.2 MODEL AND TYPE

MULCHE TC	FRONTAL MULCHE TC
<input type="checkbox"/> TC0 - 50 / 70	<input type="checkbox"/> TC1F 120
<input type="checkbox"/> TC1 - 60 / 80 / 100	<input type="checkbox"/> TC2F 140
<input type="checkbox"/> TC2 - 80 / 100 / 120	<input type="checkbox"/> TC3F 160 / 180
<input type="checkbox"/> TC3 - 110 / 130	<input type="checkbox"/> TC4F 200 / 220
<input type="checkbox"/> TC4 - 110 / 130 / 150	

Serial number.....

4.3 MANUFACTURER

CANGINIBENNE s.r.l.

Via Savio, 29-31 - 47027 Sarsina (FC) - Italy
 Tel. 0547-698020 - Fax 0547-698021

4.4 UKCA MARKING

This attachment satisfies the essential safety prerequisites of annex I of Directive UKCA Supply of Machinery (Safety) Regulations 2008, as certified by the enclosed declaration of conformity and the marking on the nameplate.

4.5 EC MARKING

This attachment satisfies the essential safety prerequisites of annex I of Directive 2006/42/EC (Machinery Directive), as certified by the enclosed declaration of conformity and the marking on the nameplate.

4.6 RELEVANT STANDARDS

Standard: UNI EN ISO 12100:2010

Title: Safety of machinery - General principles for design - Risk assessment and risk reduction.

5 DESCRIPTION OF THE IMPLEMENT

5.1 GENERAL DESCRIPTION

The implement illustrated in this manual is built solely for garden and park maintenance, for trimming hedges and bushes and above all for cutting grass.

It can be applied to articulated booms in general.

The implement can also be fitted with a variety of accessories designed for specific functions.

The list of these accessories and their functions is provided in the “Optional Kits” section of this manual.



ATTENTION

This manual contains information about accessories which may not have been chosen when the implement was purchased. Contact your local dealer if you wish to purchase them.

5.2 MAIN COMPONENTS

5.2.1 Front floating device (for front Mulcher only)

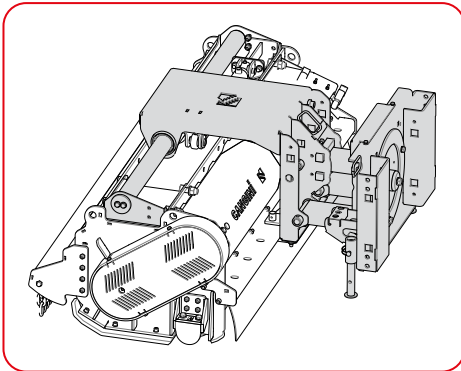

When mounted on the front cutter head, the floating device ensures that the weight of the machine does not overload the implement, preventing damage and allowing it to move more freely and smoothly when at work.

It also enables the implement to adapt to undulating ground without constant corrections by the operator, for a better job.

The machine boom should be kept in a position such that the floating device is near the centre of its range of action when the cutting head is resting on the ground.

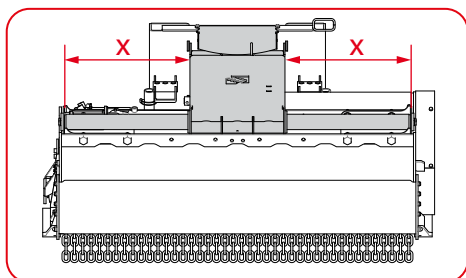

 **DANGER**

The performance of repairs or adjustments with the machine in operation is absolutely forbidden.

For TC2F, TC3F and TC4F

 **ATTENTION**

When handling and transporting the attachment, the floating device must be locked using the pin B.

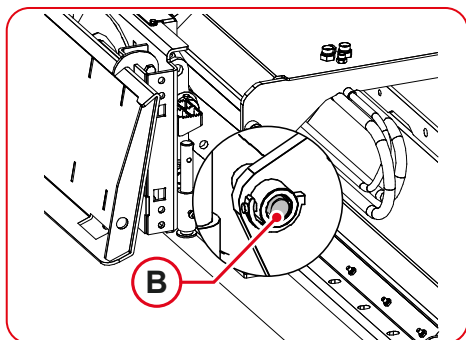

In normal working conditions, the floating device must be able to turn freely.

 **DANGER**

Use of the attachment with the floating device locked is forbidden.

To enable the floating device, proceed as described below:

- remove the pin retainer **A**;

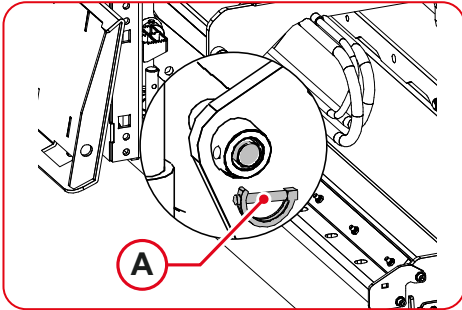

- extract the pin **B**;
- fully insert the pin **B** into the hole **F**;
- secure the pin **P** with the pin retainer **A** provided.

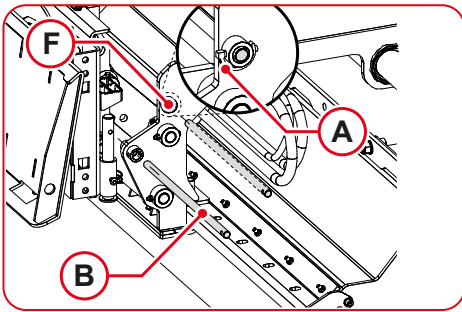

i ATTENTION

*The pin **B** must be conserved to allow it be reused whenever the floating device has to be locked for handling of the attachment.*

5.2.2 Implement swing

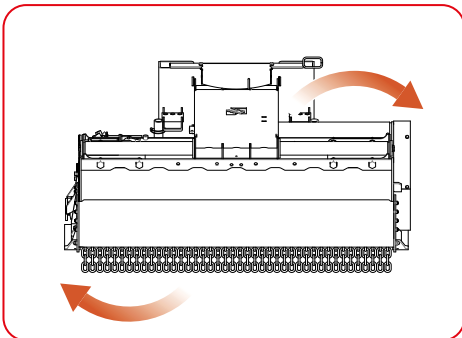

Horizontal swing = $\pm 10^\circ$

This allows the head to adapt to changes in the slope of the ground across the machine's travel direction, up to a maximum of eight degrees clockwise or anticlockwise.

It is standard on all front cutter heads.

5.2.3 Mechanical position adjustment system (for front TC2F - TC3F - TC4F Mulcher only)

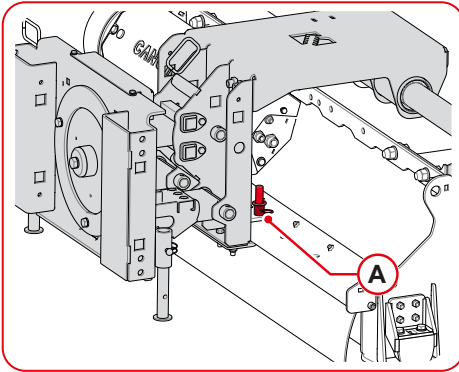

The standard frontal cutter head does not have hydraulic position adjustment, but can be adjusted mechanically by proceeding as follows:

- with the cutter head mounted on the machine, rest it on the ground and make sure that the floating device is about halfway through its operating stroke.
- switch the machine off;
- engage the parking brake;
- stop the engine;
- get off the machine;
- remove the pin (A);
- get onto the machine;
- start the engine.

- Move the machine slowly in the direction opposite to the one in which you wish to shift the implement, without lifting it off the ground; the floating device will slide along the rods.

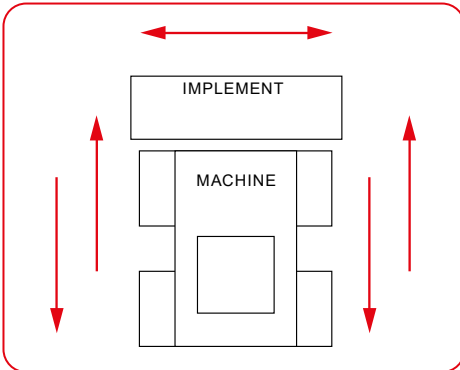

Once the required position is achieved, the following operations must be repeated:

- switch the machine off;
- engage the parking brake;
- insert the pin (A);
- start work again.

5.2.4 Floating device on mini- excavators (optional) - for TC1, TC2, TC3, TC4 only

It enables the attachment tool to adapt to undulating ground without constant corrections by the operator, for a better job.



The performance of repairs or adjustments with the machine in operation is absolutely forbidden.

Under normal working conditions, the equipment is free to rotate around the **AXES a) and b)**. In this way it is able to adapt to the undulating ground or to the machined surfaces.

In the case of special machining needs, you can lock the floating device in the most suitable position between the two available (1 or 2).

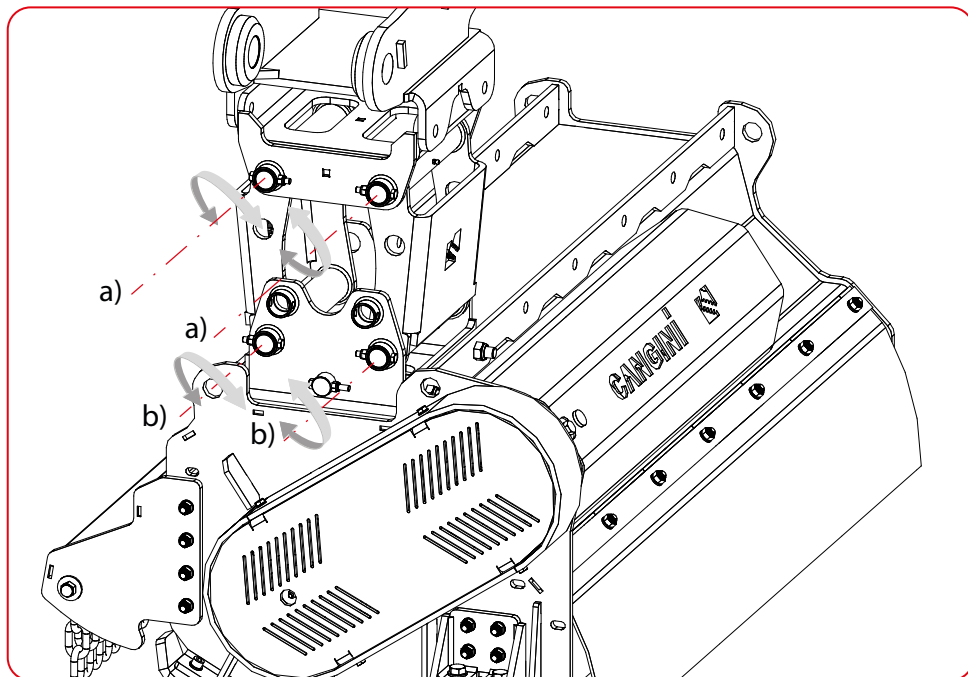

To lock the floating device, proceed as described below:

- align the hole **D** to the hole **E** or **D1** to **E1**;



DANGER

NEVER use your fingers to check that the holes are aligned.

- remove the locking device **C**;
- remove the pin **P**;
- fully insert the pin **P** into the aligned holes;
- secure the fixing pin **P** using the pin lock **C** provided.

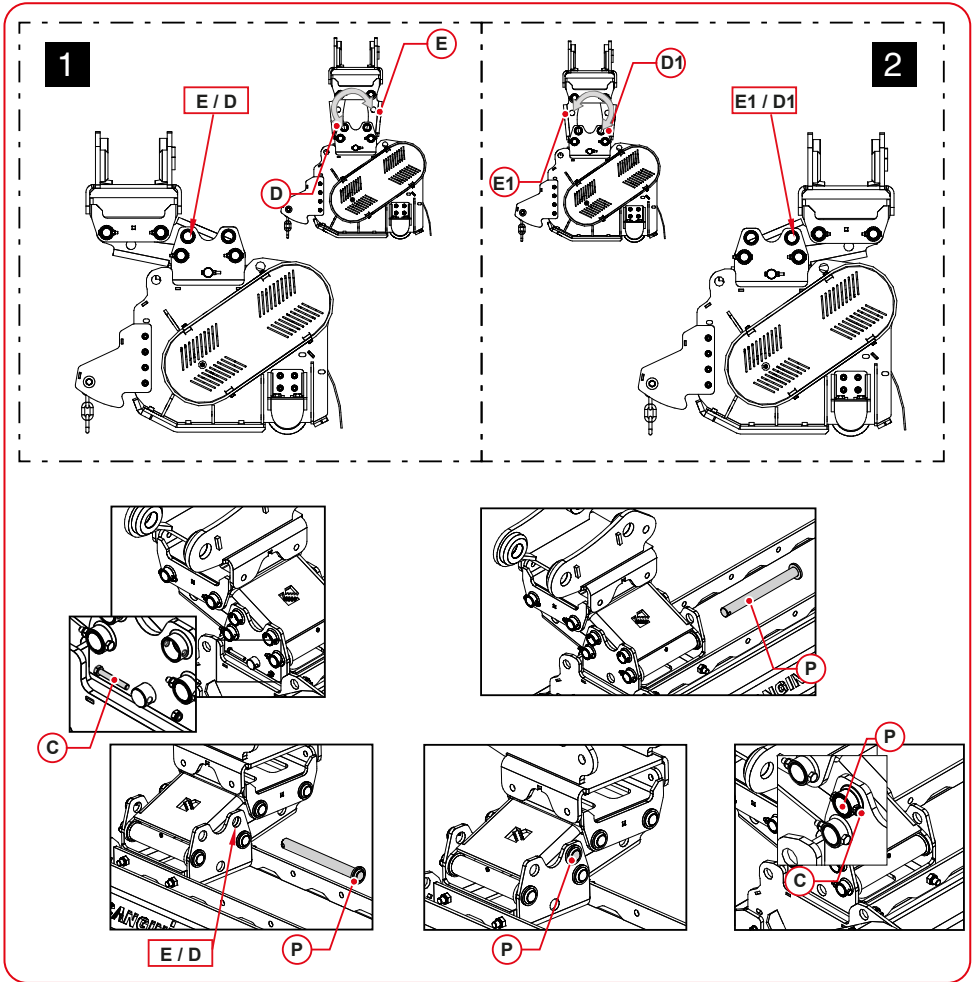

5.2.5 Hydraulic slewing ring (optional)

The device (F) converts hydraulic energy into rotational movement.

With the aid of this actuator, the end implement can be rotated.

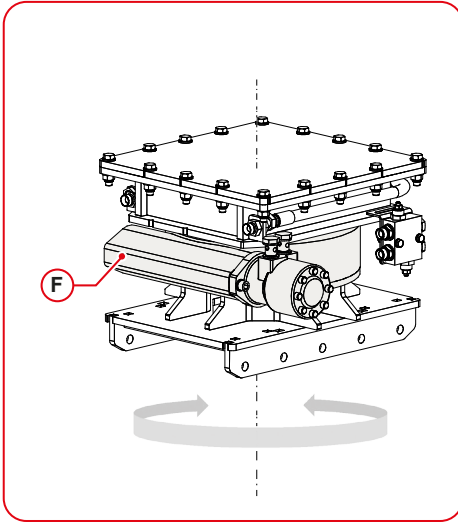

5.3 OPERATING PRINCIPLE

This implement is powered by a hydraulic transmission, by means of a hydraulic motor.

The model **TC1** has the motor directly engaged with the rotor, while the other models have a reversible pulley drive.



ATTENTION

The motor rotation speed must be 2500 ± 100 .

6 TECHNICAL DATA

The technical data are stated in this machine's declaration of conformity and on the manufacturer's nameplate affixed to the product.

6.1 SPECIFICATIONS AND MAIN DIMENSIONS

Mulcher TC

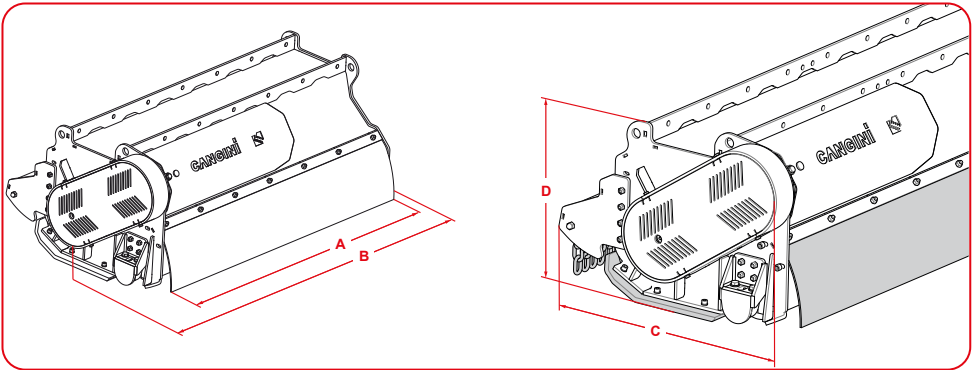

MODELS	TC0 50	TC0 70	TC1 60	TC1 80	TC1 100	TC2 80	TC2 100	TC2 120	TC3 110	TC3 130	TC4 110	TC4 130	TC4 150
WEIGHT OF MACHINE (ton)	<i>The suitable combinations will be recommended on the basis of the machine's characteristics</i>												
A (mm)	500	700	600	800	1000	800	1000	1200	1100	1300	1100	1300	1500
B (mm)	715	915	800	1000	200	980	1180	1380	1280	1480	1300	1600	1800
C (mm)	516		640			810			830		855		
D (mm)	417		461			530			575		620		
weight without attachment (kg)	70	83	100	115	125	245	270	300	375	412	455	505	540
belt (n°)	DIRECT					2					3		
shaft Ø	55		80			114			133				
max oil flow rate (l/min)	14		18			28			55		65		

MODELS	TC0 50	TC0 70	TC1 60	TC1 80	TC1 100	TC2 80	TC2 100	TC2 120	TC3 110	TC3 130	TC4 110	TC4 130	TC4 150
min oil flow rate (l/min)	depends on the CC of the motor		90						150				
maximum pressure (bar)	250						280						
Ø cutting max (mm)	15 - 20		20 - 30			40 - 60			60 - 80		80 - 100		
speed rotation (rpm/min)	2000 ÷ 2800												

Hydraulic slewing ring (optional)

TECHNICAL DATA	
ROTATION ANGLE (G°)	360°
MAX OIL FLOW RATE (l/min)	30
MAXIMUM PRESSURE (bar)	80

Front TC Mulcher TCF

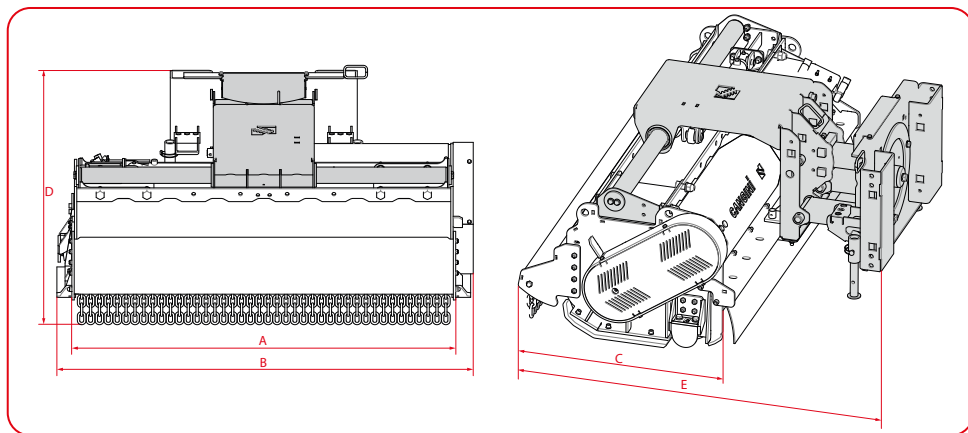

MODELS	TC1F 120	TC2F 140	TC3F 160	TC3F 180	TC4F 200	TC4F 220
WEIGHT OF MACHINE (ton)	<i>The suitable combinations will be recommended on the basis of the machine's characteristics</i>					

MODELS	TC1F 120	TC2F 140	TC3F 160	TC3F 180	TC4F 200	TC4F 220
A-working width (mm)	1200	1400	1600	1800	2000	2200
B-overall width (mm)	1405	1580	1780	1980	2200	2400
C-height (mm)	640	810	830		855	
D-depth (mm)	510	485	555		575	
E-total depth (mm)	800	1300	1320		1380	
weight without attachment (kg)	175	550	610	650	820	860
belt (n°)	DIRECT	2			3	
min oil flow rate (l/min)	22	28	55		65	
max oil flow rate (l/min)	90		150			
max pressure (bar)	250		280			
Ø cutting max (mm)	20 - 30	40 - 60	60 - 80		80 - 100	
bilateral mechanical translation (right-left) (mm)	/	± 350	± 525		± 700	± 875
bilateral hydraulic translation (right only kit with 2 tubes) (mm)	/	450				
speed rotation (rpm/min)	1800 ÷ 2800					

ATTENTION

The data provided in the table above refer to the implement without quick coupling system and possible optionals. The actual weight of the implement can be obtained from the Declaration of Conformity (page 3).

6.2 APPLICABILITY LIMITS

DANGER

The choice of attachments for use on construction is particularly important because if the applicability limits are not complied with, the attachment might cause the machine to overturn or the attachment itself could fail.



ATTENTION

When the machine on which the attachment is to be installed is known, the connections are provided by CANGINIBENNE.



WARNING

When this is not possible, the consignee will be responsible for ensuring that the stability of the machine-attachment combination is guaranteed with a suitable safety margin.



WARNING

In order to enable the consignee to achieve a correct machine-attachment combination, below CANGINIBENNE provides all the relevant details of its attachment.

In order to ensure the stability of the machine the equipment will be mounted on, perform the following check to make sure that the grapple-machine combination will work in safety.

- Check the **lifting capacity - Y - in the worst working condition** of the machine (in kg) in the machine specifications (ISO 10567-92, SAE J1097 standards).
- If the capacity includes the weight of the standard bucket mounted on the machine, add this weight (kg) to it.

The applicability limits must be calculated by subtracting

- 1) **X** = Empty weight (the maximum weight of the attachment given in the Declaration of Conformity on page 3)

from the load that operating head - **Y** - can lift (given in the machine Manual).

Y - X = L (applicabilty limit)

- If the resulting value (**L**) is **higher than ZERO** the safety condition is ensured and it is therefore **possible** to mount the equipment on the machine.
- Otherwise, working in safe conditions is not ensured and coupling **is not allowed**.



ATTENTION

The safety condition described above ensures the stability of the machine working on flat, horizontal and solid ground.

6.3 AMBIENT CONDITIONS

The implement is able to oeprate with ambient temperatures between **+ 50°C** and **- 20°C**; for different tempratures, contact your dealer or get in touch with **CANGINIBENNE** directly.

7 HANDLING

All handling operations must be carried out only by operators qualified to use the necessary equipment.

When handling, the operator must ensure that safety conditions are complied with, to protect himself and the other operators involved from injury.

Ensure that there is no-one behind and/or in front of the machine during any work done from the ground by staff assisting the user of this implement.

Insist and ensure that any service work on the implement and/or to assist the operator is always performed from a position beside the machine, and in all cases from a position which is guaranteed to be safe.

7.1 LIFTING

When lifting the implement:

- use only lifting accessories which bear the CE marking (2006/42/CE) and UKCA marking The Supply of Machinery (Safety) Regulations 2008
- connect only to the points shown.

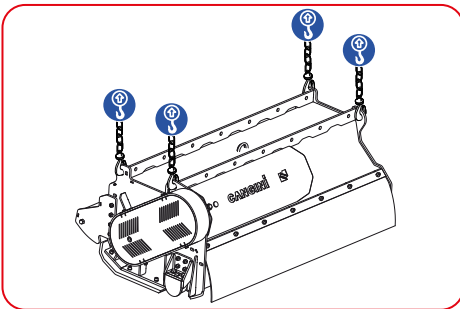

DANGER

Make sure that the crane, the slings as well as the fork truck are proper for lifting the machine (lifting capacity greater than the weight as given in the Declaration of page 3)

DANGER

Do not pass or stand underneath the implement during lifting.

DANGER

The handling of the attachment must be carried out using the lifting points.

DANGER

Attention: the implement oscillates during the lifting phase

8 INSTALLATION

The machine-attachment hitching system may vary depending on the model of machine. For linkages other than those shown below, follow the instructions in the machine's operator's manual.

8.1 ATTACHMENT MOUNTING AND REMOVAL INSTRUCTIONS

8.1.1 Mounting on the attachment support frame

This type of installation is recommended for continual and heavy-duty use. Since the attachment support frame of every machine is different, we will simply provide general information on this type of installation. More detailed information for installation of the attachment on each individual machine must be requested from the Manufacturer.



WARNING

Ensure that the skids and feet are resting firmly on the ground and that the attachment is horizontal and resting firmly on the ground.

To install the attachment on the machine correctly, proceed as follows:

- bring the front of the machine towards the rear of the attachment's frame, aligned centrally with it, and stop about 50 cm away;

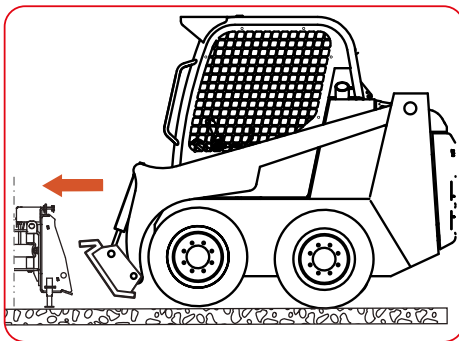

- turn the levers to release the machine's quick linkage system;
- turn the levers to release the attachment's top links;

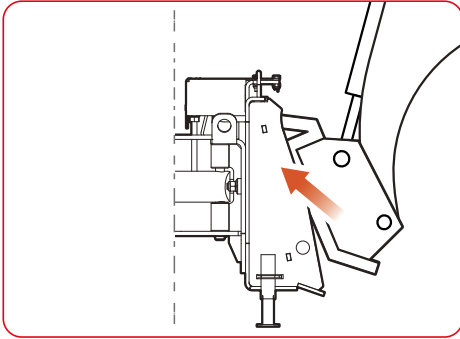

- lower the machine's connection plate and tilt it forward;
- move the machine closer and insert the connection plate underneath the connection provided on the attachment, taking great care to ensure that the links are perfectly aligned.

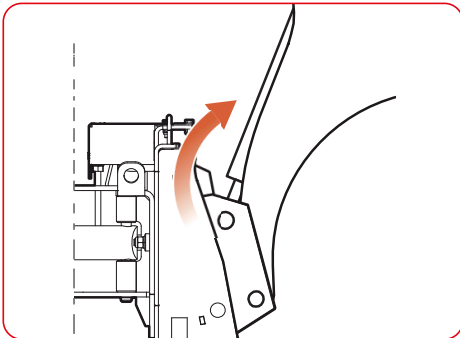

⚠ OVERTURNING HAZARD

During all hitching operations, use the machine at extremely low speed and operate the controls very gently and carefully, to ensure the attachment does not overturn.

- Lift the machine's connection plate slightly and tilt its top back a little to allow the machine's bottom supports to engage with those of the attachment's frame.
- Lock the levers of the machine's connection plate by turning them into the locked position.
- Align the top linkage points with the supports fitted on the machine.

- Check that the wedges or pins of the quick linkage devices are firmly inserted in place.
- Lock the levers of the top supports by turning them into the locked position.
- Connect the snap connections of the hoses of the attachment's hydraulic system to their connections on the machine's auxiliary hydraulic system. The hoses have different snap connections (male and female) to ensure that the two hoses cannot be swapped.



ATTENTION

Clean the snap connections thoroughly before fitting them to ensure that no dust or dirt can enter the hydraulic circuit.



- Remove the locking device **A** and raise the supporting foot **B**;

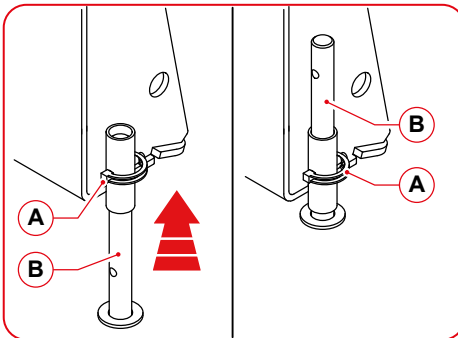

- refit the locking device **A** lock the supporting foot into the new position; repeat the operation for the supporting foot on the other side of the equipment.

**DANGER**

*Use of the attachment with the floating device locked is forbidden.
To enable the floating device, proceed as described in point 5.2.1.*

Once the attachment mounting operations are complete, start the machine's auxiliary hydraulic circuit and check that the controls function, operating them carefully one at a time. Also check that there are no oil leaks.

**ATTENTION**

Leaks of hydraulic fluid from the pressurised circuit may cause:

- burns;
- injuries;
- infections.

Therefore put on gloves, goggles and suitable clothing (PPE) before looking for any leaks.

**WARNING**

Never use your hands to look for leaks in the circuit; use protective screens (cardboard or wood).

With the engine off, turn the attachment's operating knobs and disconnect the hoses which connect it to the machine.

8.1.2 tructions for demounting the attachment

- Move to the area of level, solid ground where you wish to deposit the attachment;
- Operate the machine controls and lower the equipment to the ground.
- Remove the locking device **A** and lower the supporting foot **B**.

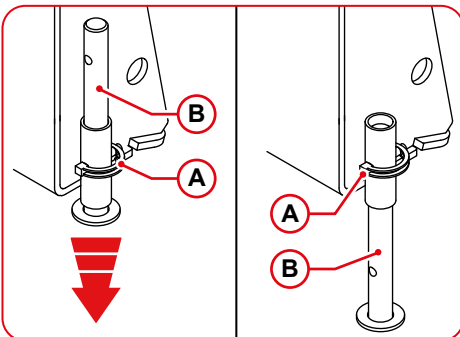

- Reposition the locking device **A** and lock the supporting foot into the new position; repeat this operation for the supporting foot on the other side of the equipment.
- Stop the machine.
- Alternately operate the control lever to release any residual pressure in the hoses.
- Disconnect the flexible hoses from the quick-fit couplers of the auxiliary line of the machine;

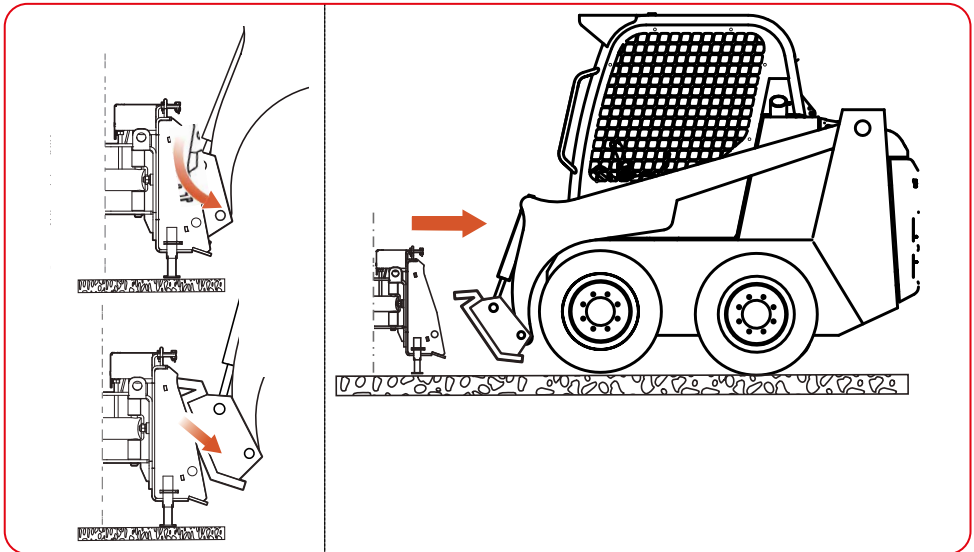

- Place the equipment in a safe and steady position.
- Unlock the attachment operating the special device on the machine quick-fit coupling.
- Move back slowly with the machine and remove the quick-fit coupling from the supporting plate.

8.1.3 Installation on mini-excavators with quick coupling system



WARNING

If the attachment is fitted with a different quick coupling system, for the fitting and dismantling instructions see the Use and Maintenance manual for the quick coupling itself.

The steps in the procedure for mounting the attachment on the machine are described below.

- Place the attachment firmly on the ground on a flat, compact surface;
- connect the top of the machine's quick coupling system to the top connection pin on the attachment;
- operate the machine's controls to connect the bottom part of the coupling system;
- operate the mechanism which locks the bottom part of the coupling system.

**DANGER**

After coupling the attachment, before using it perform a visual inspection to ensure that it is connected correctly; incorrectly connected attachments may be hazardous for the operator or for people and property in the working area.

- Stop the machine safely;
- make the connection (hydraulic or electrohydraulic) between the attachment and the machine as described in the "Connections" section;
- now start the machine and slowly operate the various moving parts of the attachment to pressurise the entire hydraulic circuit.

8.1.4 Uncoupling the attachment

To uncouple the attachment, proceed as follows:

- move to the zone where you wish to deposit the attachment, which must be on level, solid ground;
- operate the machine's commands to place the attachment firmly and safely on the ground;
- switch the machine off;
- operate the control lever to discharge the residual pressure from the delivery pipelines;
- disconnect the hoses from the snap connections of the machine's auxiliary line; also disconnect the electrical connection, if any;
- start the machine;

- operate the mechanism which unlocks the bottom part of the coupling system;
- reverse the machine slowly and at the same time extract the backhoe loader's quick-fit hitch from the attachment's coupling.

8.2 CONNECTIONS

8.2.1 Hydraulic connection

The illustration below shows the **IN** and **OUT** connections of the valve unit, to which the machine's hoses must be connected.

Mulcher TC 0

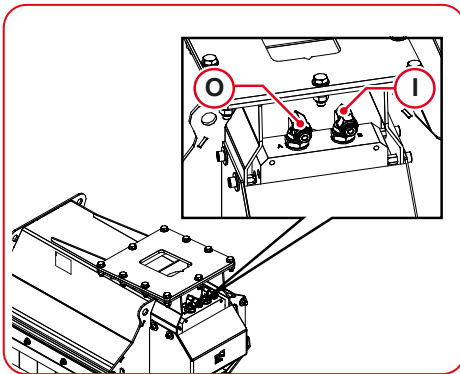

Mulcher TC 1

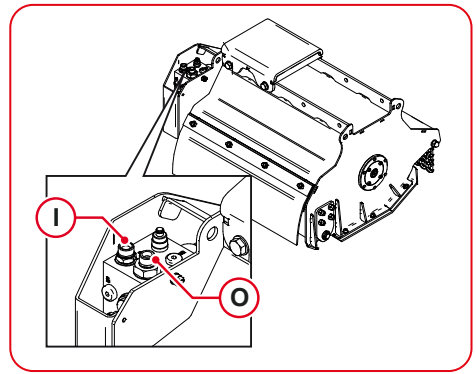

Mulcher TC 2

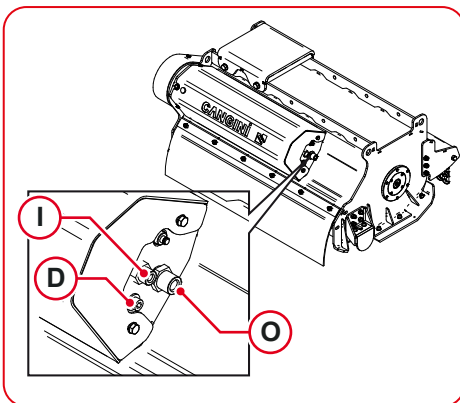

Mulcher TC 3-4

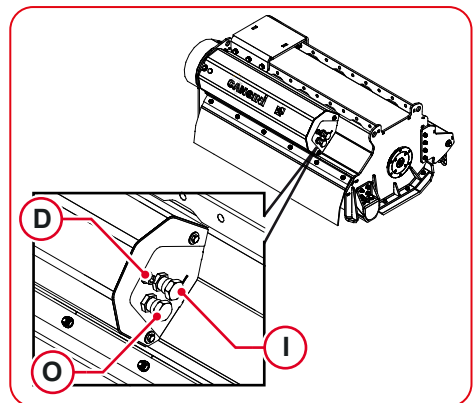

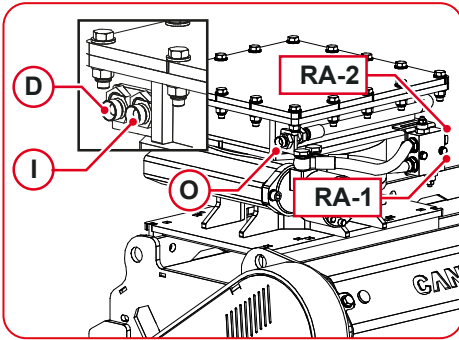
With hydraulic slewing ring (optional)

- **I**) Inlet hose (**IN**).
- **O**) Outlet hose (**OUT**).
- **D**) Drain line outlet connection.
- **RA-1**) Input motor slewing ring (Ø 1/2" GAS)
- **RA-2**) Output motor slewing ring (Ø 1/2" GAS)

△ WARNING

With PISTON MOTOR a drain hose directly connected to the machine's tank must be installed (the drain line backpressure must not exceed 2 bar).

Failure to comply with this recommendation will lead to a failure of the motor and the loss of warranty cover.

△ WARNING

With GEAR MOTOR, if the backpressure on the return line exceeds 10 bar, a drain hose directly connected to the machine's tank must be installed.

Failure to comply with this recommendation will lead to a failure of the motor and the loss of warranty cover.

EXCAVATOR TC MULCHER	TC 0	TC 1	TC 2	TC 3	TC 4
I (IN) INTLET HOSE	1/2" gas			3/4" gas	
O (OUT) OUTLET HOSE	1/2" gas		3/4" gas		

Front TC Mulcher Models TCF

Front Cutter Heads come complete with the following machine connection hoses.

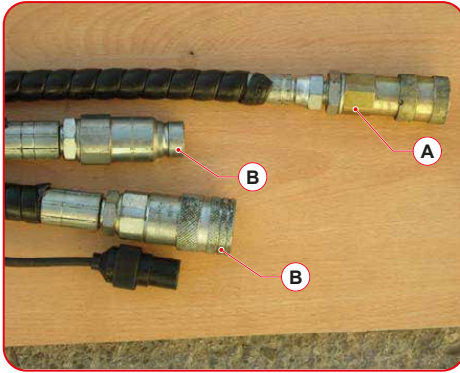

A) 3/8 hose (With GEAR MOTOR)

- 1/2 hose (With PISTON MOTOR)

B) 3/4 hose

Connect the hoses to the machine's auxiliary line.

- Connect the hose (A) to the return line leading to the tank.
- Connect the two 3/4 hoses (B) to the machine's hydraulic line.



WARNING

With PISTON MOTOR a drain hose directly connected to the machine's tank must be installed (the drain line backpressure must not exceed 2 bar).

Failure to comply with this recommendation will lead to a failure of the motor and the loss of warranty cover.



WARNING

With GEAR MOTOR, if the backpressure on the return line exceeds 10 bar, a drain hose directly connected to the machine's tank must be installed.

Failure to comply with this recommendation will lead to a failure of the motor and the loss of warranty cover.

8.3 MAINTENANCE AND INSTALLATION DEVICES

8.3.1 Drive belt and belt stretcher

In this attachment (except for the cutting head **mod. TC0 and TC1**), the tool shaft is driven by means of V-belts. The belt tension is adjusted by means of a stretcher device, proceeding as follows:

- stop the engine, remove the ignition key and engage the parking brake;
- remove the casing **A** by undoing the bolts;

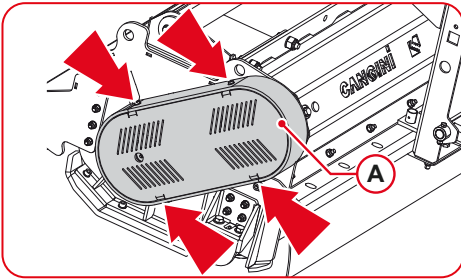

- remove the casing **B** by undoing the bolts;

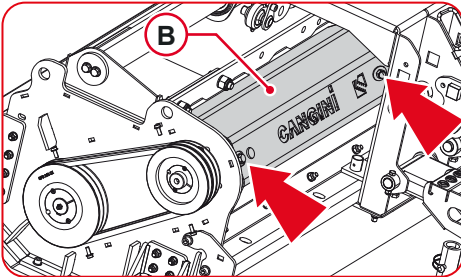

- undo the nuts **C** of the support;

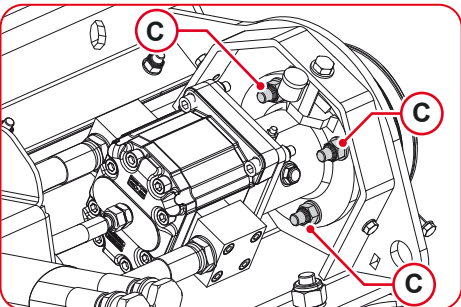

- slide the top pulley support along the mounting slot in the frame, using the screw provided **D**;

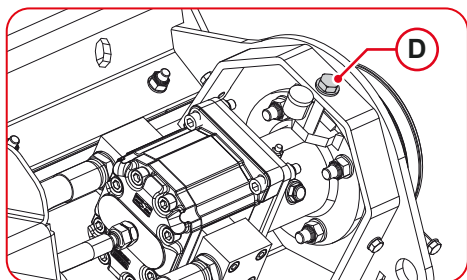

- check that the tension is correct, considering that a pressure N of 50N should cause a dip in the belt x of 5mm;

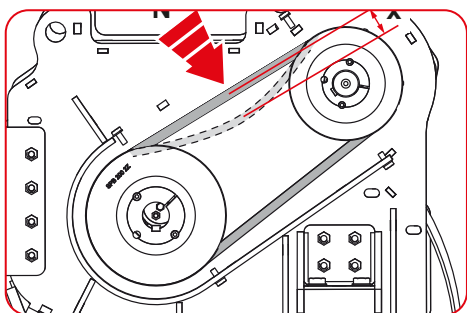

The belts are very important components in this attachment, so they must be checked every 8 hours for wear and damage, checking that there are no cracks or fraying.

- reassemble the protective casings **A** and **B** and retighten all the bolts.

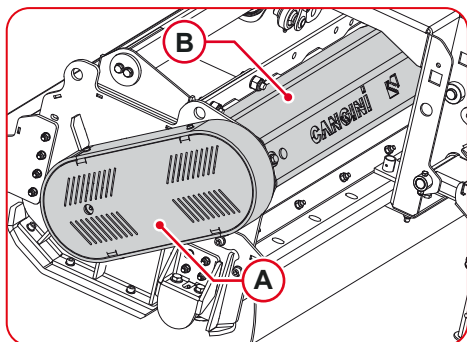

**DANGER**

Never use this attachment without the protective casings fitted.

**WARNING**

Never check belt tension or rotation with the protective casing removed.

**WARNING**

All operations involving the drive system must only be carried out by skilled staff.

If the belts require replacement, proceed as follows:

- stop the engine, remove the ignition key and engage the parking brake;
- remove the casing **A** by undoing the bolts;

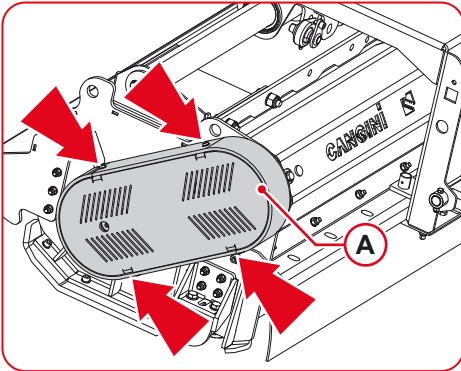

- remove the casing **B** by undoing the bolts;

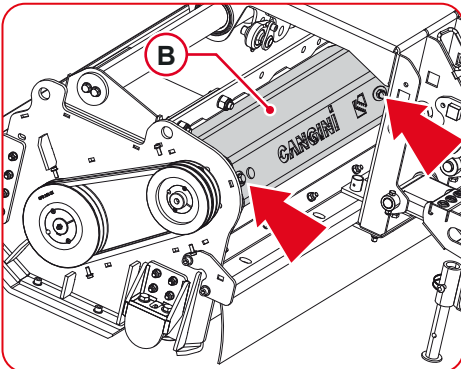

- undo the nuts **C** of the support;

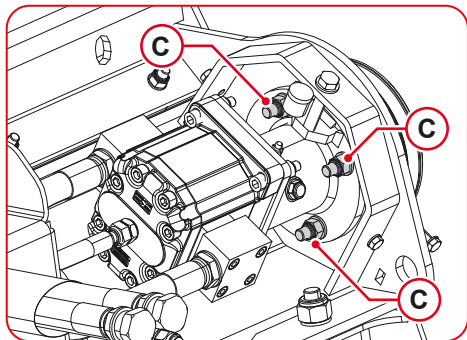

- slide the top pulley support **E** to the back end of the mounting slot in the frame, loosening the screw **D** to free the belts and allow their removal;

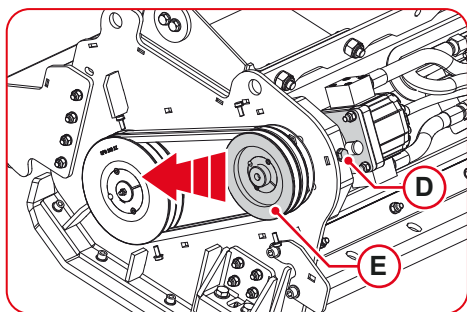

- replace all the belts **F** at the same time. The difference in length between the belts must not exceed strict tolerance levels. Check that the belts are properly fitted into the pulley races and are correctly aligned and parallel;

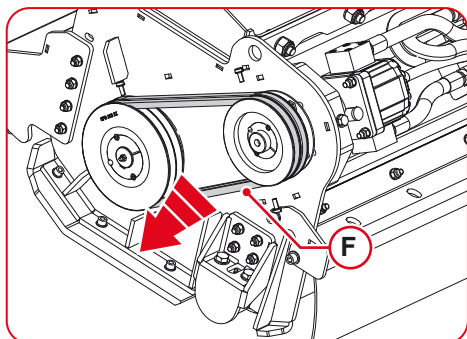

ATTENTION

Use of genuine spare parts ensures interchangeability.

- after setting the belts at the correct tension, reassemble the protective casings **A** and **B** and retighten all the bolts.

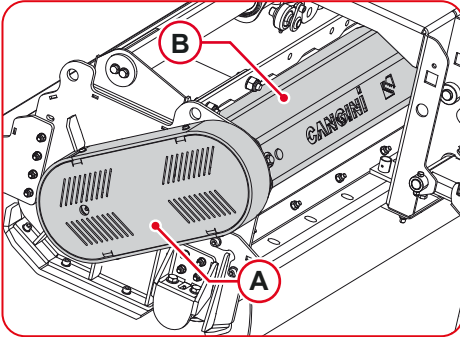
DANGER

Never use this attachment without the protective casings fitted.

8.3.2 Working tools

Depending on the material for cutting, the attachment can be fitted with STANDARD or LARGE SLICER KNIVES in heat-treated special steel.

STANDARD KNIVES are reversible, since they have sharp edges on both sides. This means that when the first side is worn, the knives can be overturned to use the opposite side.

LARGE SLICER KNIVES are not reversible.

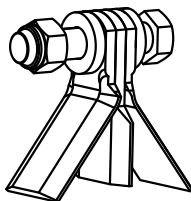
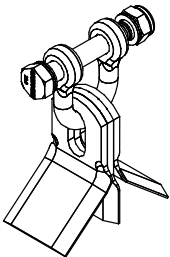
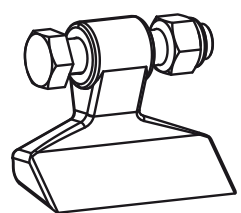
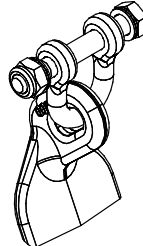
STANDARD KNIVES
LARGE SLICER KNIVES
TC0 / TC1
TC2 / TC3 / TC4

TC0 / TC1
TC2 / TC3 / TC4

! DANGER

It is strictly forbidden to modify the tools equipment of the rotor.

In the same rotor, the equipment of knives CANNOT be replaced by mallets, and vice-versa.

! DANGER

As well as being dangerous for the user and other people and potentially damaging to the machine, its improper use leads to the irreparable loss of warranty cover.

8.3.3 Recommendations for use

△ WARNING

Inspect for wear and damage daily, especially in the connection points. Check the tightness of the connection bolts.

In the event that knives break due to working accidents, they must be replaced at once to avoid causing rotor imbalance.

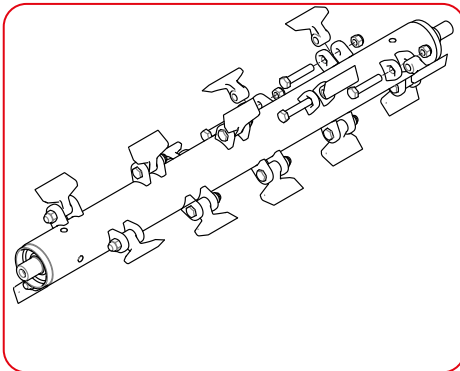

It is best always to replace cutting tools in diametrically opposed pairs, even if only one is broken.

In the event of wear of the cutting tools after prolonged use, the entire set must be replaced, even if they are not all worn to the same extent.

i ATTENTION

Rotor balancing parameters will only be met if genuine parts are used.

△ WARNING

Before each use, check that there are no items tangled around the rotor.

Also check that the rotor turns freely in its run direction.

8.4 SAFETY DEVICES

8.4.1 Safety flaps

- A)** The textile-reinforced rubber skirts on the rear of the attachment not only act as a guard but also reduce the speed of cut material flung out at dangerously high speed.
- B)** The skirts or protective chains at the front of the attachment prevent cut material and/or objects from being flung towards the machine during operation.
- C)** The side guards guarantee that the bottom edge of the side panels is below the working diameter of the tools, for safety reasons.

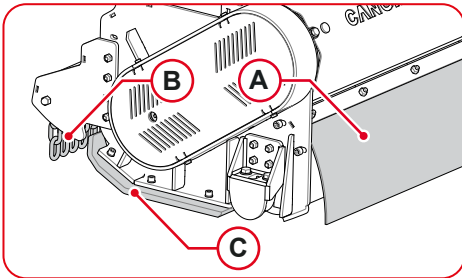

Mulcher TC0

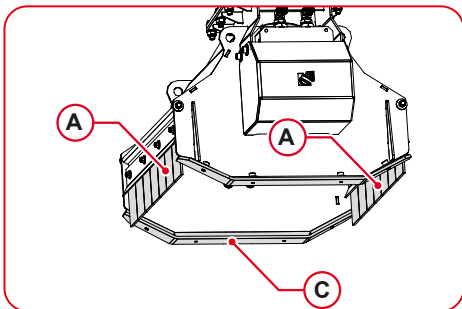

 **DANGER**

These safety guards must never be removed from the attachment.

 **DANGER**

Inspect all the guard fittings for wear and damage daily, and replace if worn and/or damaged. The manufacturer refuses all responsibility in the event of accidents due to use of the attachment without the safety devices foreseen.

9 USING THE ATTACHMENT



DANGER

No-one must stand inside the danger area while the machine is in operation.

Before using the attachment, it is of fundamental importance to:

- become familiar with the positions and functions of the attachment's specific controls;
- check that the attachment and machine are free from malfunctions or failed or missing parts;
- check that the procedure and maintenance operations specified in this manual and the machine manual have been completed and understood;
- check that the connection between the attachment and the machine has been made correctly and there is no risk of accidental uncoupling;
- check that the hydraulic connections are securely fixed;
- check that all the machine's controls are off before the engine is started.

9.1 CONDITIONS OF USE

The machine on which the attachment is mounted must only be used by qualified staff familiar with the layout and functions of all the controls and the instructions provided on the various signs.



DANGER

The performance of repairs or adjustments with the machine in operation is absolutely forbidden.



DANGER

Stop the attachment at once and switch off the engine of the machine at the first sign of danger. Identify the causes and remove them before restarting work.



DANGER

Before performing any maintenance and/or adjustment procedure, stop the cutter head, ensure that no parts are in motion, even by inertia, and place it on the ground or on stable stands which will ensure it cannot fall during maintenance.

**ATTENTION**

The working zone should be inspected so that any objects such as wire, fencing, metal posts and any other items which may cause damage and/or hazards during the use of the attachment can be removed or reported to the operator.

9.2 OPERATION

Once in the working area, to start work proceed as follows:

- 1) Lower the cutter head to about 5 cm above the ground.
- 2) At low speed, operate the auxiliary hydraulic control and accelerate the cutter head to top speed.
- 3) Lower the machine boom, completely lower the cutter head and start work.

**DANGER**

If the cutting head is used more than 5 cm above the ground, take care over the flying object hazard.

**ATTENTION**

Always drive the machine in a straight line. Never turn with the attachment resting on the ground as this may cause damage and apply excessive sideways thrust to the parts in contact with the ground.

**WARNING**

When working overhead and when cutting grass and scrub on the ground, a hazard is generated in the attachment's area of operation due to the risk of falling branches or objects flung even a long distance at ground level. Before starting work, check that all the guard devices are in good working order

9.2.1 TC0 mulching head - Reversing the rotation direction

With the **TC0** cutting head, the tool shaft rotation direction can be reversed.

**DANGER**

ALWAYS wait for the tool shaft to stop before reversing the rotation direction.

The diagram illustrates correct use of the attachment depending on the tools with which it is fitted.

STANDARD KNIVES are reversible: they can be used in conditions A and B.

LARGE SLICER KNIVES are not reversible: they can only be used in condition A.

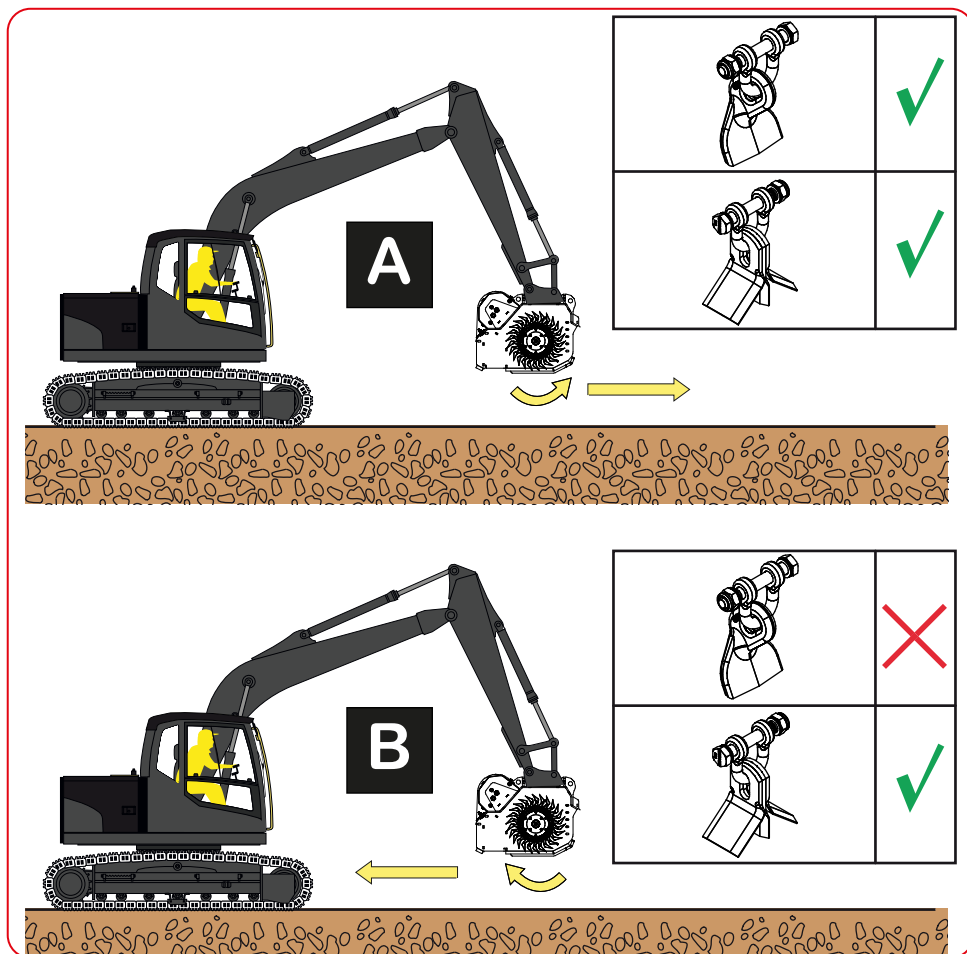

9.3 ADJUSTING THE ATTACHMENT

9.3.1 Adjusting the cutting height - on TC1, TC2, TC3, TC4 models

The cutting height above ground level can be adjusted by varying the position of the supporting roller, using the bolts on the sides of the head.

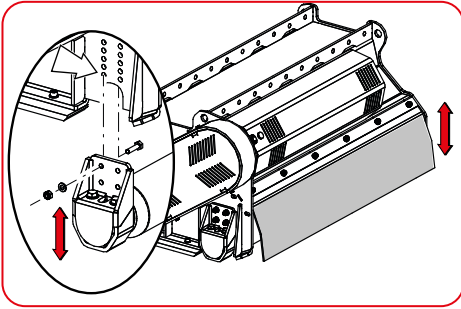
**ATTENTION**

For even cutting, the roller must be perfectly parallel to the rotor.

**DANGER**

Before proceeding with any repairs or adjustments on this attachment, ensure that the machine on which it is installed is stationary with the parking brake engaged and the ignition key removed to ensure that no-one can start it accidentally. Discharge the residual pressure from the system.

9.4 TRAVEL ON THE PUBLIC HIGHWAY

Travel on the public highway is regulated by the relevant legislation in every single country.

Do not use the machine plus attachment on the public highway unless the application has been approved in accordance with the relevant regulations and recorded in the machine's logbook.

The Manufacturer declines all responsibility for the consequences of failure to comply with the highway code or the instructions provided in this manual.

**WARNING**

When driving on public roads, scrupulously obey the provisions of the local highway code.

9.5 LENGTHY LAY-OFFS

Follow the instructions provided below to prepare the attachment for lengthy periods out of use:

- clean and completely degrease the attachment;
- store the attachment under cover in a dry place, and cover it with a tarpaulin;
- inspect the attachment thoroughly and replace any damaged and/or worn parts;
- fully tighten all nuts, screws and bolts.

9.6 SCRAPPING

The attachment must be scrapped by skilled staff in accordance with the relevant legal requirements:

- do not dump non-biodegradable products, lubricating oils and non-metal components (rubber, PVC, plastics, etc.) in the environment;
- when scrapping, sort components by chemical type and recycle where possible.



PROTECT THE ENVIRONMENT

During disposal, collect any oil or grease spills in suitable containers. Do not dump them in the environment; contact authorised collection centres.

10 OPTIONAL KITS

The attachment can be equipped with the following optional accessory:

- hydraulic side shift system.

10.1 HYDRAULIC SIDE SHIFT SYSTEM

The side shift system allows the cutter to be used outside the width of the machine, so that the operator can cut beside the machine.

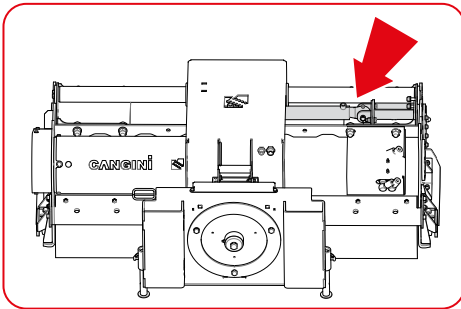

When the side shift system is operated, the attachment moves sideways along its own axis.

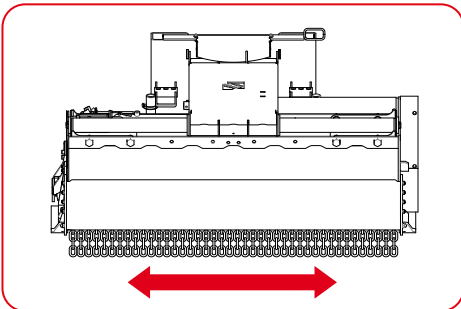

WARNING

Operate the machine for a few minutes without load, using all the cylinders (one at a time) to bleed the air from the hydraulic circuit. This operation must be carried out the first time the attachment is mounted on the machine, or whenever the cylinders start to operate in jerks.

10.1.1 Connection and operation of the electric kit provided

If the attachment is fitted with the hydraulic side shift system, a ready-assembled electric kit will be provided for operation of the solenoid valve which allows the cylinder to move the attachment to the right or left of the driving position.

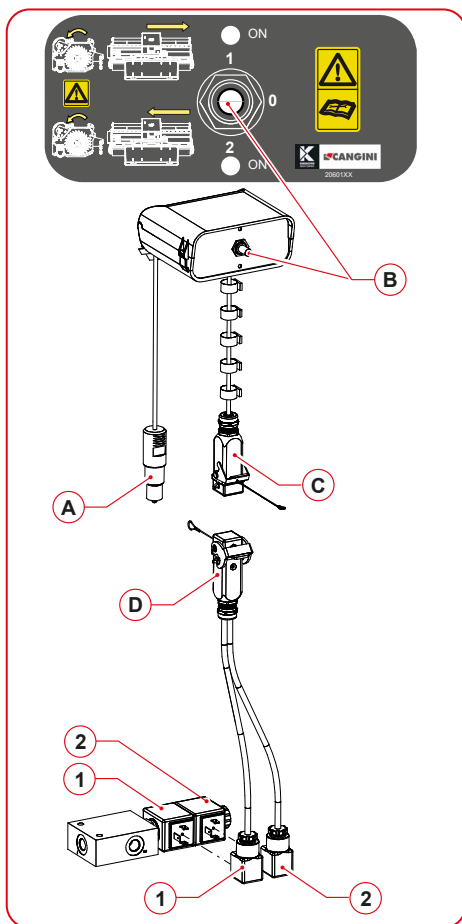

A) Cigarette lighter socket.

B) 1 - 0 - 2 switch.

C) Socket.

D) Plug.

To install it, simply fit the plug into the machine's cigarette lighter socket.

If the machine does not have one, an electrician will have to connect up a 12 Volt power supply for the kit.

- Secure the wire inside the cab so that it does not in any way interfere with the machine's manoeuvrability or functions.
- Use the adhesive tie plates and ties provided to secure the wire firmly;
- fix the 3-setting switch box so that it does not interfere with any machine control functions;
- lay the wire along the boom of the machine so that it does not interfere with or risk being sheared by its articulated joints when in motion.
- Continue to fix using adhesive tie plates, bringing the socket close to the machine's hydraulic connections.

Now simply connect the socket **C** of the kit just installed to the plug **D** in the attachment.

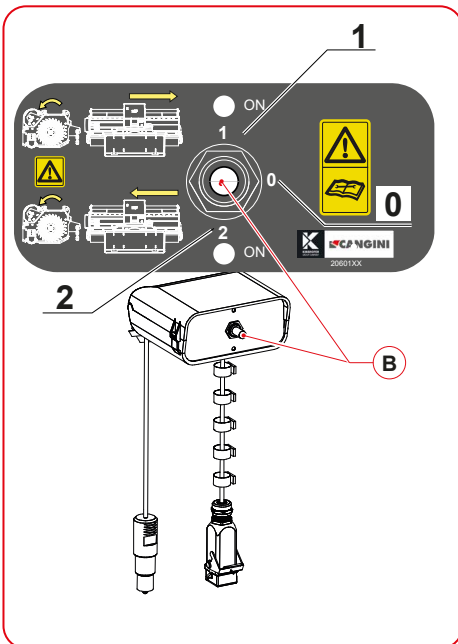

To operate the side shift system, turn the switch **B** from **0** to **1** to supply the hydraulic circuit. The attachment will move to the right.

To operate the side shift system to the left, turn the switch **B** from “**0**” to “**2**” to supply the hydraulic circuit.

Return the switch B to “0” before starting cutting.



DANGER

The tool shaft is turning during shifting of the cutting head.

Before adjusting the attachment’s sideways position, proceed as follows:

- lift the attachment a few centimetres above the ground using the boom of the machine,
- move the switch **B** from **0** to **1** or **2**;
- supply fluid to the auxiliary output;
- move the attachment to the position required.
- Turn the switch **B** back to **0**.
- Slowly rest the attachment on the ground, bringing the floating device to the centre of its stroke;
- start cutting.

10.1.2 Electrical connection for optional hydraulic side shift

Once the cutter head has been connected to the machine, the user has only to operate the electric control and supply fluid to the system to move the cutter head sideways.



ATTENTION

NEVER move the cutter head sideways without first lifting it a few centimetres above the ground.

11 MAINTENANCE

Every shift

- Check the general conditions of the attachment.
- Make sure there are no oil leaks.
- Check that there is no evident damage to the hydraulic system.
- Check that the safety pictograms are present and legible.

Every 100 working hours

- Check for correct hydraulic connections.
- Check that the hydraulic hoses are in good condition.

Every 500 working hours

- Check that connection pins are free of wear and play.
- Perform a visual inspection of the welds: check that they are free from cracks, deformation, wear, failures or rust. If in doubt about the condition of the weld, contact **CANGINIBENNE**.

Only regular maintenance procedures recommended by the manufacture will keep the attachment in good working order and safe.

- Check that all components are in good condition, there are no oil leaks and the guards are in place and operating correctly.
- Clean the attachment completely at the end of each working shift.



ATTENTION

Failure to comply with the maintenance instructions provided in this manual automatically cancels the CANGINIBENNE product warranty.



ATTENTION

For maintenance instructions for components not directly produced by the manufacturer, refer to the enclosed original technical documentation.

 **DANGER**

All attachment inspection and/or maintenance procedures must be carried out with the machine off and in a stable, safe position.

 **ATTENTION**

All extraordinary maintenance procedures carried out on the attachment must be recorded in the tables, annexed to this manual. Always provide this manual to the CANGINIBENNE engineer as a record of any work done.

 **DANGER**

Discharge the pressure from the attachment's hydraulic system before any maintenance operations.

 **ATTENTION**

Leaks of hydraulic fluid from the pressurised circuit may cause:

- burns;
- injuries;
- infections.

Therefore put on gloves, goggles and suitable clothing (PPE - not supplied by Manufacturer) before looking for any leaks.

 **WARNING**

Never use your hands to look for leaks in the circuit; use protective screens (cardboard or wood). With the engine off, turn the attachment's operating knobs and disconnect the hoses which connect it to the machine.



**DANGER**

Before any maintenance, repair, cleaning and adjustment operation,

- *lower the attachment to the ground,*
- *stop the engine of the machine, eliminate any residual pressure from the hydraulic system*
- *and put a warning sign inside the cab.*

To eliminate the residual pressure, operate the auxiliary comand of the rotor several times with the engine stopped. Also depressurize the hydraulic oil tank of the machine.

11.1 ROUTINE MAINTENANCE

Within the first 8 working hours

- Check the tightness of the bolts and pipeline unions.

At the start of every working shift

- Check the skirts or the chains that provide the protective screen against flung-out debris to ensure that they are not damaged. If one or more chains are damaged and/or misshapen and do not provide the complete protection originally guaranteed, stop work. Order genuine replacement parts from Canginibenne and do not start work again until the protective screen has been completely restored.

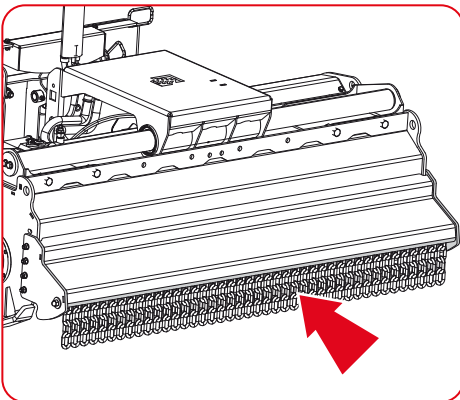

Every 4 working hours

- Check the tightness of the knife fixing bolts;
- grease the side bearing blocks of the knife rotor (see Par. 11.2.2).

Every 8 working hours

- Grease the bearing blocks of the rear roller (when fitted) using the grease nipples provided.
- check the tension of the drive belts.
- grease the supporting of the motor, using the grease nipple provided (see Par. 11.2.2 **Mulcher TCTC2, TC3, TC4**)

Every 10 working hours

- Check the tightness of all the nuts and bolts.

Every 50 working hours

- Inspect the hydraulic system;
- grease all moving parts of the side shift system;

For inspection and maintenance, the rear casing must be opened with the machine at a standstill. Secure it safely in place.



ATTENTION

The machine must not be used with the casing open, for any reason.

11.2 MAINTENANCE PROCEDURES

11.2.1 Greasing



WARNING

Before injecting lubricating grease into the nipples, they must be cleaned carefully to prevent mud, dust and/or dirt from mixing with the grease, making the lubrication ineffective.

- Inject grease into the grease nipples provided using a pump.
- Place the attachment on the ground, switch off the operating machine engine and remove the ignition key.
- Inject grease through the appropriate grease nipples with a pump. Stop greasing once fresh grease is seen to seep from the crevices.

 **WARNING**

All parts for greasing are marked on the attachment with the symbol shown below.

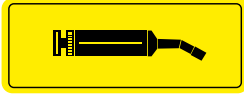

Then eliminate excess grease.

 **PROTECT THE ENVIRONMENT**

Do not dump grease in the environment; dispose of it in accordance with the relevant legislation, at authorised collection centres.

 **DANGER**

The user must directly acquire the safety data sheets relating to the substances substituted during the life of the machine. Said sheets are subject to regular updates, due to development of the specific regulation.

The attachment is filled with grease TYPE: KP2K-30 according to CLASSIFICATION of LUBRICATING GREASES **DIN 51 502**.

A lubricating grease with the same technical characteristics has to be used

11.2.2 Grease points

MULCHER TC2, TC3, TC4

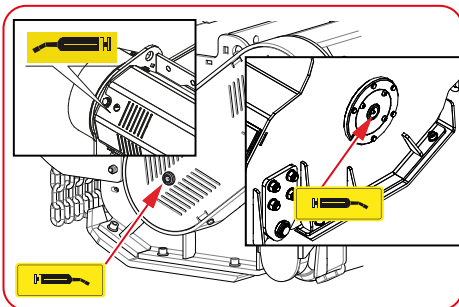

MULCHER TC1

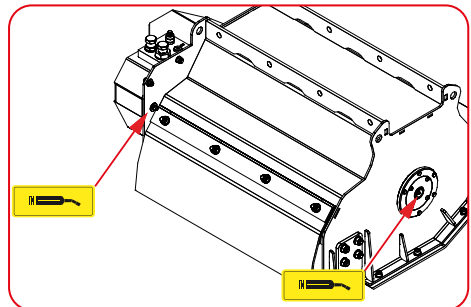

MULCHER TC0

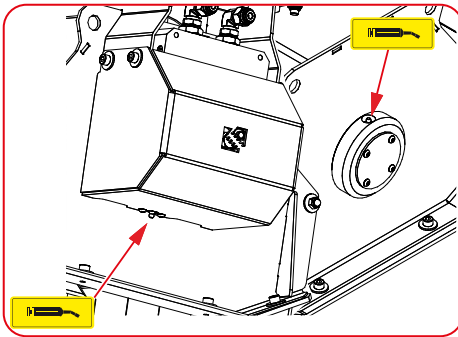

11.2.3 Changing the knives

If knives require replacement, proceed as follows:

- uncouple the attachment from the machine;
- place the attachment on a workbench with the aid of certified lifting equipment (see “Lifting” chapter):
- ensure that the attachment is firmly positioned and cannot slip or fall;
- **Mulcher TCTC2, TC3, TC4**

Remove the nose **A** by undoing the bolts, in order to access the knives.

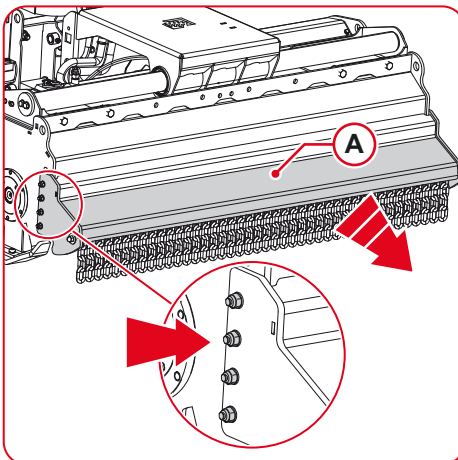

MULCHER TC1 - TC0

Release and extract the supporting bar **T** in order to access the knives.

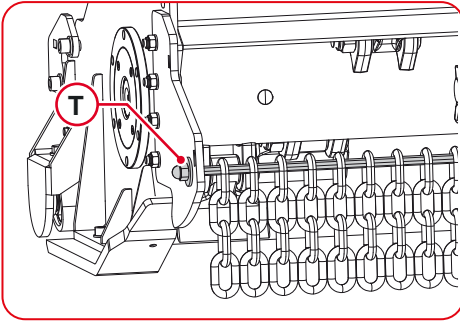

- take out the bolt **B** which secures the knife and remove it;
- fit the new knife, taking care to use a new bolt.
- replace the nose **A** or the supporting bar **T**, tightening the bolts.

 **WARNING**

Knives must only be replaced with the engine off and the hydraulic system disconnected.

To ensure that the rotor is correctly balanced, cut the new tool to reduce its weight to the same as that of the other tools, which are already worn.

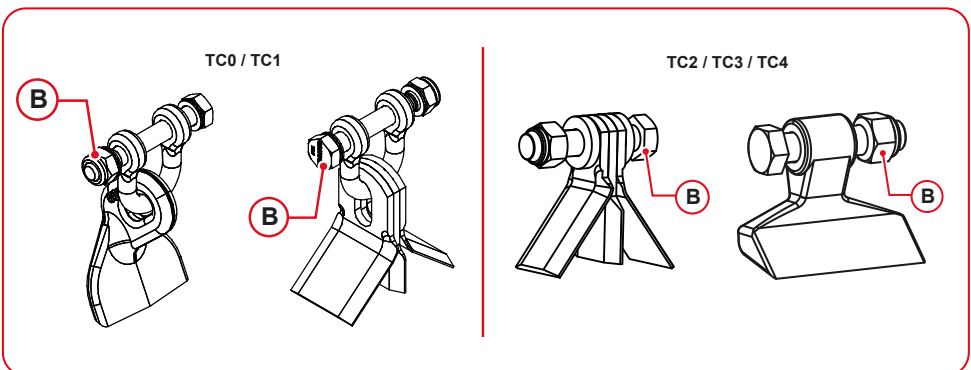

11.2.4 Replacing the guards

Inspect the front guards daily.

Replace any which are broken or bent at once.

11.2.4.1 Replacing the stone guard chains (for TC1, TC2, TC3, TC4 only)

Release and extract the supporting bar **A** until the guard for replacement comes away, then reinsert the bar and fix it in place.

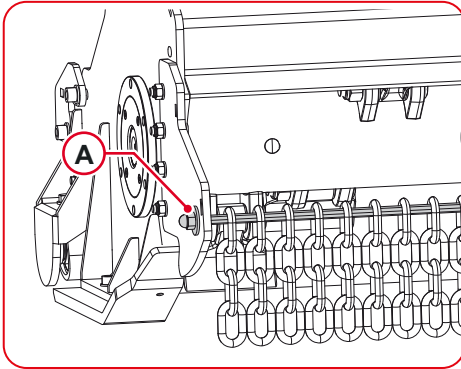

11.2.4.2 Replacing the stone guard skirts (for TC0 only)

- Remove the bolts **B** and remove the plate **A**.
- Replace the skirt **S**.
- Replace the plate **A** and secure using the bolts **B**.

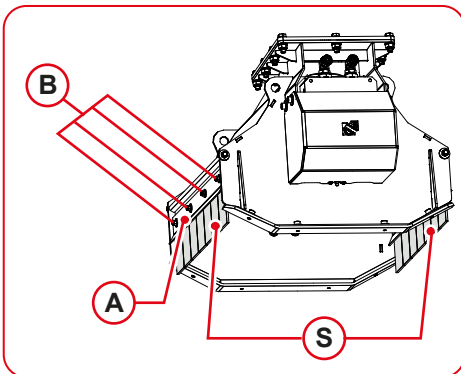

12 TROUBLESHOOTING

The table below is provided in order to allow identification of the causes which may lead to malfunctions or nonoperation of the attachment and their correction.

PROBLEMS	CAUSES	REMEDIES
Uneven cutting	- Blunt knives	- Sharpen the knives
	- Missing knives	- Fit the missing knives
Uneven cutting height	- Depth roller not parallel	- Check and adjust if necessary
The rotor slows down when the machine moves	- The hydraulic system is not supplying enough fluid	- Check the auxiliary delivery rates with the machine in motion; if necessary fit a priority valve system
Rotor does not turn	- Pressure insufficient	- Check working pressure
	- Jammed objects blocking rotation	- Clean the rotor
	- Belts slack or worn	- Stretch or replace if necessary (see Point 8.3.1)
	- Bearings have failed or damaged	- Contact CANGINIBENNE .
	- Fluid flow direction incorrect	- Swap connections P and T
Rotor vibrates	- Blunt tools	- Sharpen the tools
	- Missing tools	- Fit the missing tools
	- Rotor unbalanced or damaged	- Contact CANGINIBENNE .
	- Bearings have failed or damaged	- Contact CANGINIBENNE . - Control ingrease of the parts
CONTACT THE MANUFACTURER FOR ANY PROBLEMS NOT INCLUDED IN THE CHART.		

13 WARRANTY CONDITIONS

The warranty covering defects in material and manufacture is valid for 12 (twelve) months from the delivery date, and is subject to the following conditions:

- 1) the only valid document for the purposes of the warranty is the declaration of conformity which accompanies the goods, and which must therefore be conserved by the customer for presentation as appropriate.
- 2) Any defects detected in the goods must be reported to **CANGINIBENNE S.r.l.** and suitably documented by means of a written technical report and/or photographs where circumstances require. Faulty products shall be returned to **CANGINIBENNE S.r.l.**, which will inspect them and, if appropriate, repair or replace them within the time necessary for the relative work, without any charge for parts or labour.

13.1 ITEMS NOT COVERED BY THE WARRANTY

- 1) The warranty does not cover damage to the hydraulic motors, if the counterpressure on the download advanced over 10 bar and the third tube of water-drainage is not installed, attached directly to the tank of the machine.
- 2) Carriage will be payable by the customer, who shall organise it or place it in the hands of **CANGINIBENNE S.r.l.**, which will charge for the relative expenses.
- 3) Under no circumstances shall **CANGINIBENNE S.r.l.** (or the authorised dealer) be considered responsible for the cost of work stoppages, unavailability of the implement for use, or other consequent or special incidental damages.
- 4) The warranty does not cover damage arising from misuse or any use not compliant with the specifications explained in the Operator's Manual supplied with the product. Nor does it cover damage due to normal wear and tear of the product.
- 5) **CANGINIBENNE S.r.l.** shall not provide any warranty in the event of:
 - total or partial failure to perform maintenance;
 - negligent use of the implement;
 - the use of machine-implement combinations not permitted by **CANGINIBENNE S.r.l.** on the customer's own initiative;
 - repairs and/or modifications to the articles covered by the warranty without the prior written authorisation of **CANGINIBENNE S.r.l.**;
 - failure to comply with payment terms.

- 6) **CANGINIBENNE S.r.l.** does not grant any type of warranty not specifically stated.
- 7) Any waivers of the above must be authorised in writing by **CANGINIBENNE S.r.l.**
- 8) **CANGINIBENNE S.r.l.** is not liable for damage or accidents to people or property caused by the owners of **CANGINIBENNE** implements.
- 9) No agent, dealer or representative is authorised to issue warranties in the name of **CANGINIBENNE S.r.l.** except as specified above.
- 10) For all warranty requests, always state:
 - model;
 - serial number;
 - date of purchase;
 - dealer's name.
- 11) Any disputes arising with regard to this manual which cannot be settled by agreement between the parties shall be subject to the laws of the Republic of Italy and the Forlì Law Court shall have jurisdiction.

14.2 ANNEX - B ELECTRICAL - HYDRAULICAL SYSTEM WITH REGULATOR VALVES

14.2.1 TC Mulcher models TC0

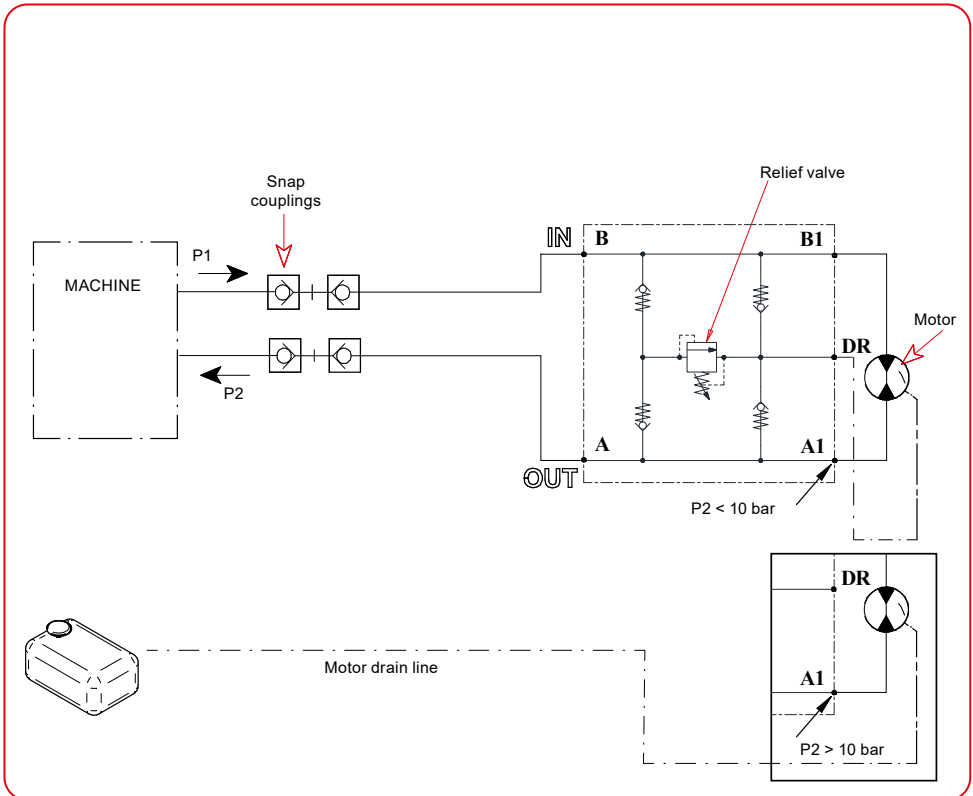

14.2.2 TC Mulcher models TC1, TC2 and TC1F

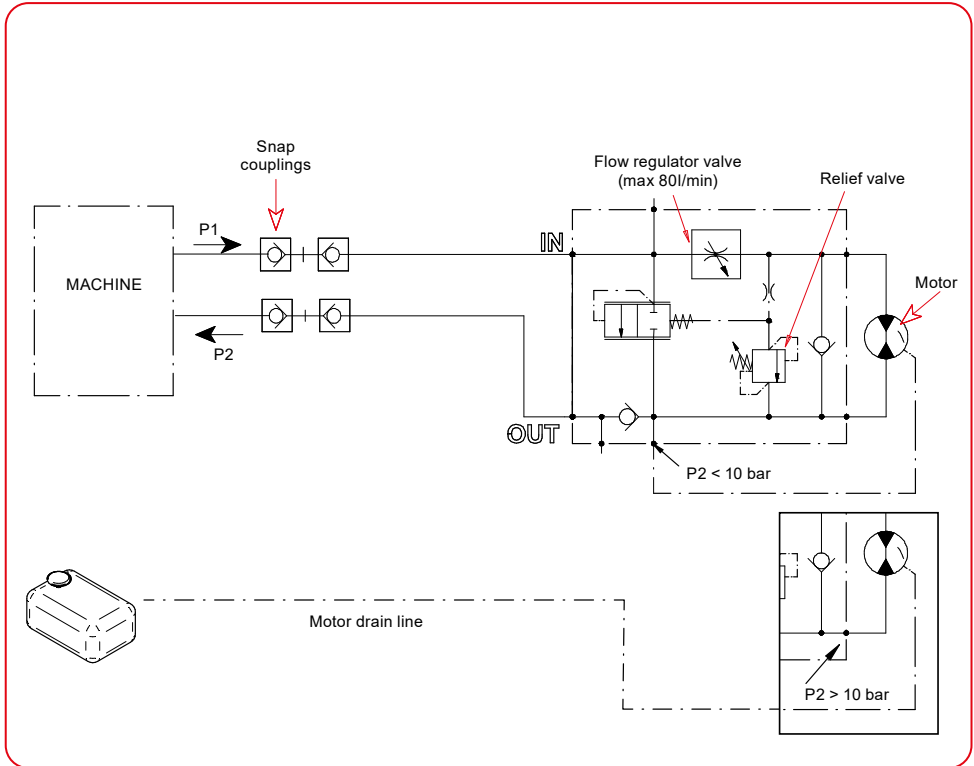

14.2.3 TC Mulcher model TCF2

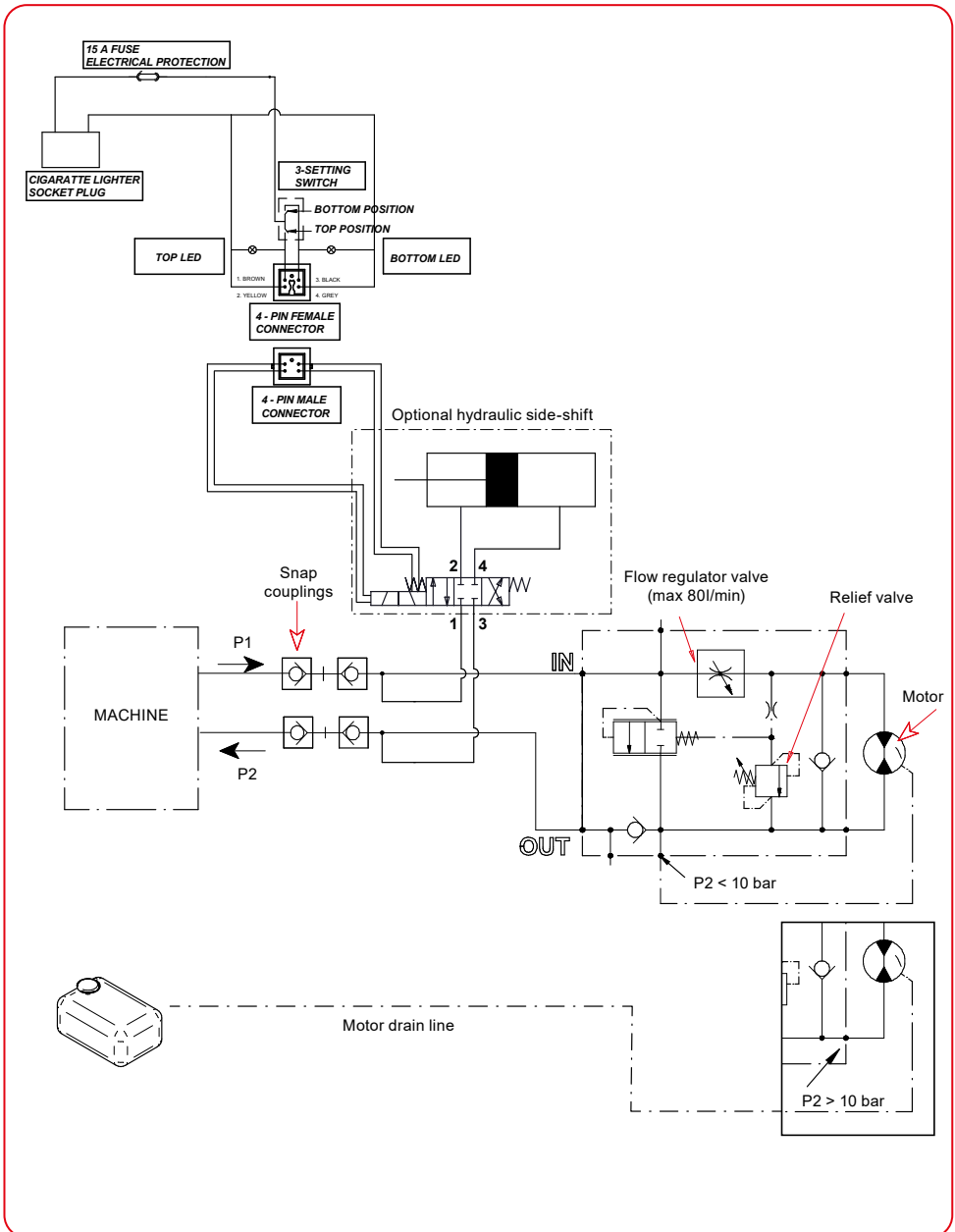

14.2.4 TC Mulcher models TC3 and TC4 (gear motor)

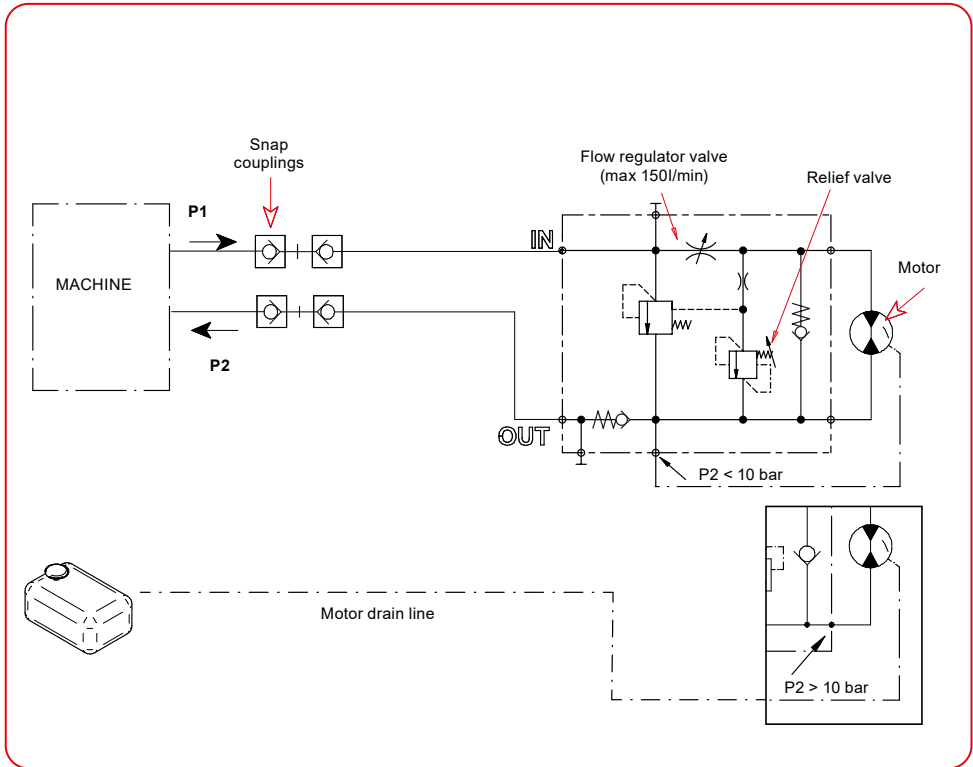

**14.2.5 TC Mulcher models TC3 and TC4
(piston motor)**

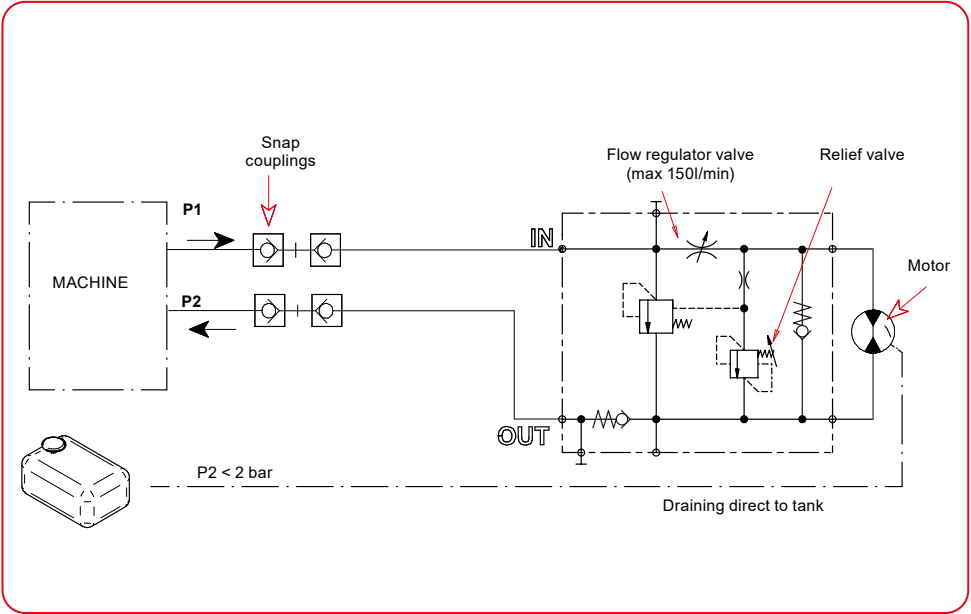

14.2.6 TC Mulcher models TCF3 and TCF4 (gear motor)

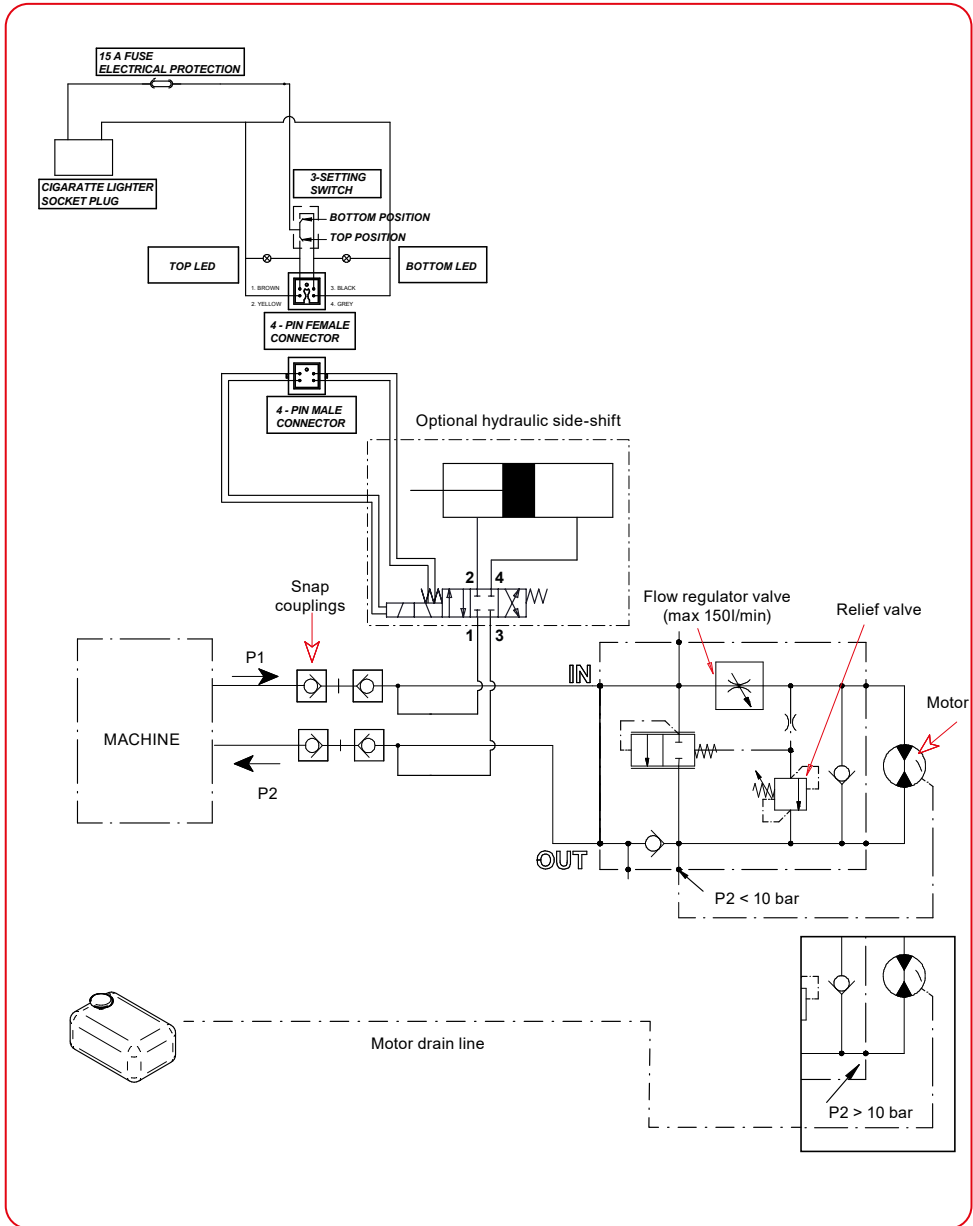

14.2.7 TC Mulcher models TCF3 and TCF4 (piston motor)

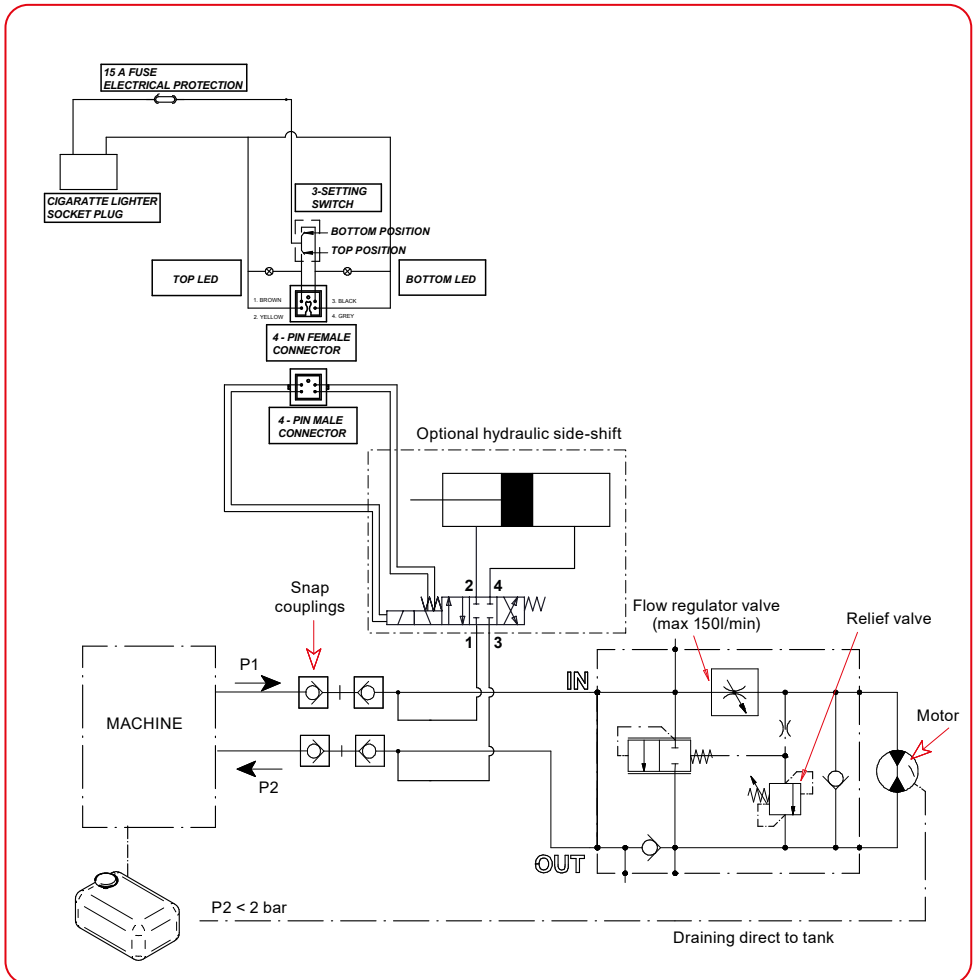



A series of horizontal dotted lines spanning the width of the page, intended for handwritten notes.

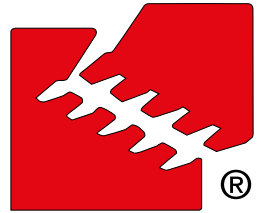

CANGINIBENNE srl

Via Savio, 29/31

I-47027 Sarsina FC

tel. 0039 - 0547 - 698020

fax 0039 - 0547 - 698021

commerciale@canginibenne.com
www.canginibenne.com

COMPANY WITH UNI EN ISO 9001 - 2015
CERTIFIED SYSTEM