

MB-G1200

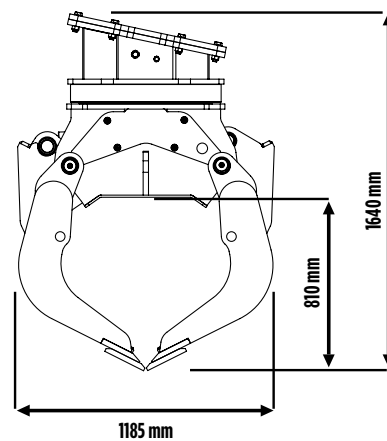

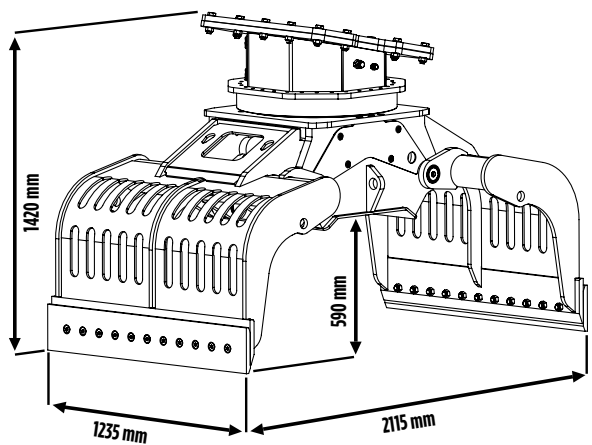

MB-G1200

The MB-G1200 grapple has been created to be used in quarries and sites that require handling of large-sized and very heavy materials. It combines notable operational agility, extreme sensitivity and hold precision, and its closing strength can be gradually increased to the point of carrying out demolitions of walls.

ACCESSORIES

- RECOMMENDED SPARE PARTS KIT
- FIXED COUPLER
- QUICK FEMALE COUPLER
- 24 MONTHS WARRANTY

AREAS OF APPLICATION

- QUARRIES
- URBAN JOB SITES
- DEMOLITION

SPECIFICATIONS

EQUIPMENT	LOAD CAPACITY (CLAWS CLOSED)	FLOW DIRECTION	OIL FLOW (OPEN/CLOSE)
 ≥ 18 ≤ 25 Ton	0,71 m ³ / 710 L	20 ÷ 35 l/min.	50 l/min.
PRESSURE OF ROTATION	PRESSURE (OPEN/CLOSE)	WEIGHT	ROTATION
200 bar	300 ÷ 400 bar	1,6 Ton	360°